

**1986
Omnical
Sound-Level Calibrator
Instruction Manual**

Copyright © 2002 IET Labs, Inc.



IET LABS, INC.
formerly manufacturer by
GenRad

534 Main Street, Westbury, NY 11590 www.ietlabs.com
TEL: (516) 334-5959 • (800) 899-8438 • FAX: (516) 334-5988

Table of Contents

Specifications	iv
Warranty	v
Condensed Operating Instructions	vi
Introduction – Section 1	
1.1 Purpose	1-1
1.2 Description	1-1
1.3 Controls, Indicators and Connectors	1-1
1.4 Accessories	1-1
Operation – Section 2	
2.1 Unpacking and Inspection	2-1
2.2 Battery Installation	2-1
2.3 Battery Check	2-1
2.4 Battery Removal	2-2
2.5 Desiccant Replacement	2-2
2.6 Transducer Assembly	2-4
2.7 Microphone Adaptors	2-4
2.8 Operational Check	2-5
2.9 Calibration of Sound-Measuring Instruments	2-7
2.9.1 General	2-7
2.9.2 Sensitivity	2-7
2.9.3 Frequency-Weighting Characteristics	2-9
2.9.4 Linearity and Tracking	2-12
2.9.5 Dynamic Characteristics	2-15
2.9.6 RMS Accuracy	2-16
2.9.7 Octave-Filter Characteristics	2-17
2.9.8 Overshoot	2-18
2.9.9 Decay Time	2-20
2.10 Altitude and Pressure Corrections	2-21
2.11 Pressure-to-Free-Field Corrections	2-23
2.12 Microphone-Volume and High-Frequency Corrections	2-24
2.13 AC Output	2-26
2.14 Use with GR 1954 Noise Dosimeter	2-27
Standards – Section 3	
3.1 General	3-1
3.2 Sensitivity	3-1
3.3 Frequency-Weighting Characteristics	3-2
3.4 Linearity and Tracking	3-2
3.5 Dynamic Characteristics	3-7
3.6 RMS Accuracy	3-8
3.7 Overshoot	3-9
Theory – Section 4	
4.1 General	4-1
4.2 Analog Circuits	4-1
4.3 Digital Circuits	4-5

Service and Maintenance – Section 5

Handling Precautions 5-1

5.1 Customer Service 5-2

5.2 Instrument Return 5-2

5.3 Performance Verification 5-2

5.4 Frequency Interlock 5-5

5.5 Disassembly 5-5

5.6 Tests and Calibrations 5-7

5.7 Trouble Analysis 5-16

Parts Lists and Diagrams – Section 6

6.1 Mechanical Parts 6-1

6.2 Electrical-Parts List and Diagrams 6-1

6.3 Federal Manufacturer’s Code 6-1

Sound Instrumentation Calibration Charts 6-10

Appendix 6-12

Specifications

Output Sound-Pressure Levels: 74, 84, 94, 104, or 114 dB re 20 μPa [†].

Nominal Output Frequencies: 125, 250, 500, 1000, 2000, or 4000 Hz.

Actual Output Frequencies: Preferred per ANSI SI. 6-1960 and ISO R266: 125.9, 251.2, 501.2, 1000, 1995 or 3981 Hz $\pm 3\%$.

Reference Conditions: TEMPERATURE: 20°C (68°F). ATMOSPHERIC PRESSURE: 1013 mbar[†] (760 mm of Hg) (30 in. of Hg). RELATIVE HUMIDITY: 65%. MICROPHONE EFFECTIVE VOLUME: 0.5 cm³ (0.03 in.³) (nominal for GR 1961 Electret-Condenser Microphone*).

Accuracy of Sound-Pressure Level: Under stated reference environmental conditions, at 114-dB SPL and at all frequencies except 4000 Hz: ± 0.25 dB for cavity alone or when used with any adaptor (except 1-1/8-in. adaptor: ± 0.5 dB at 1000 Hz only); at 114-dB SPL and 4000 Hz: ± 0.5 dB. At output levels other than 114-dB SPL, tolerance is increased by ± 0.1 dB.

Temperature Coefficient of Sound-Pressure Level: Less than ± 0.02 dB/^oC for all frequencies except 4000 Hz.

Tone-Burst Signals: Test signals provided as prescribed by ANSI SI. 4-1971; IEC Publications 123-1961, 179-1973 and 179A-1973; and Consolidated Revision of IEC Publications 123 and 179. In tone-burst modes, output can be either continuous (SET FAST/SLOW or SET CREST FACTOR) or series of bursts (FAST, SLOW or CREST FACTOR), as selected. Level is uncalibrated and continuously adjustable. In FAST or SLOW, peak amplitude of tone burst is identical to that of continuous signal. In CREST FACTOR, rms value of tone-burst sequence is identical to that of continuous signal. FAST: repeated tone bursts at 1000 Hz, 200-ms duration every 2 s, for measuring sound-level-meter FAST rise response; amplitude is continuously variable from 72 dB to 118 dB re 20 μPa ; background level is 20 dB below burst level. SLOW: repeated tone bursts at 1000 Hz, 500-ms duration every 10 s, for measuring sound-level-meter SLOW rise response; amplitude is continuously variable from 72 to 118 dB re 20 μPa ; background level is 20 dB below burst level. CREST FACTOR: repeated tone bursts at 2000 Hz, 5.5-ms duration, 40-Hz repetition rate, crest factor 3, for measuring rms detector-indicator accuracy and amplifier crest-factor capacity; rms amplitude is continuously variable from 75 to 111 dB re 20 μPa .

Variable Sound-Pressure-Level Control: Enabled only in tone-burst modes. Provides 11 dB of adjustment.

Electrical Output: Output provided from nominal 600- Ω shortable source. Voltage proportional to sound pressure; 230-mV-rms nominal output corresponding to 114-dB SPL.

Distortion: Less than 1% THD acoustical or electrical.

Power: Powered by 9-V alkaline battery; GenRad recommends Mallory MN 1604 or Eveready 522. Battery provides at least 8 h continuous operation.

Environment: TEMPERATURE; -10°C to +50°C (+14°F to +122°F), operating; -40°C to +70°C (-40°F to +140°F), storage with battery removed. HUMIDITY: 0% to 90% R.H., operating.

Mechanical: DIMENSIONS (wxhxd): Approximately 280x67x165 mm (11x2-5/8x6-1/2 in.). WEIGHT: Approximately 1 kg (2.2 lb).

Battery Test: Internal circuitry checks condition of battery continuously. Automatic instrument shutdown when battery voltage falls below acceptable range.

Microphone Coupling: Transducer cavity accommodates following 1-in. microphones: GR 1961 electret-condenser,* GR 1971 ceramic, Western Electric 640AA and Tokyo Riko MR103.

Accessories Supplied: Coupler-adaptor to accommodate GR 1962 1/2-in. electret-condenser* microphone and GR 1983 Sound-Level Meter microphone; 3 spare desiccant kits; battery; instruction manual.

Accessories Available: Adaptor set that includes coupler-adaptor for 3/8-in. GR 1954 Noise Dosimeter microphone; coupler-adaptors and "O" ring for 1-in., 1/2-in. and 1/4-in. B & K microphones, and coupler-adaptor for 1-1/8-in. Shure Brothers microphone. Carrying case.

†In the international system of units (SI) the unit of pressure is the pascal (Pa); $1 \text{ Pa} = 1 \text{ N/m}^2 = 10 \text{ dynes/cm}^2 = 10^{-2} \text{ mbar}$.
REF: "The International System of Units (SI)", U.S. Dept. of Commerce, National Bureau of Standards, NBS Special Publication 330. SD Cat. No. C13. 10:330/2, U.S. GPO, Washington, D.C. 20402.

*U.S. Patent 4,070,741.

Condensed Operating Instructions

TO ACTIVATE THE INSTRUMENT:

Set 1986 controls to 1 kHz, 114 dB and CALIBRATED SPL; listen for 1-kHz audible tone. If no tone is present, replace battery (see para 2.4).

TO CALIBRATE A SOUND-MEASURING INSTRUMENT:

- a. Observe desiccant indicator through window; if half (or more) has turned from pale blue to pink, replace desiccants (see para 2.5).
- b. Remove transducer from storage compartment and mount on microphone of instrument under test; use appropriate adaptor if necessary (see para 2.7).
- c. To calibrate sound-measuring instrument (daily procedure), perform Sensitivity Test outlined below; to verify conformity of sound-measuring instrument with specifications called out by ANSI or IEC Standards (refer to para 2.9.1), perform other 4 tests outlined below at periodic intervals.
- d. If desired, use charts on Page 6-10 (tipout) to record results.
- e. When testing is completed, replace transducer in storage compartment.

DAILY CALIBRATION – *Perform before and after each day's use:*

Sensitivity Test.

- a. Set 1986: CALIBRATED SPL, 1 kHz, LEVEL to nearest level commonly measured.
- b. Set instrument under test: LEVEL RANGE to measure high on scale for LEVEL set in step a, FAST or SLOW response, WEIGHTING as desired (normally, A WEIGHTING).
- c. Read level on instrument under test and adjust its calibration control to indicate the LEVEL selected in step a.
- d. A correction must be applied to above reading for various microphones at frequencies of 1 kHz or greater. Refer to Table A (following these instructions) for correction.

PERIODIC VERIFICATION – *Perform at regular, periodic intervals (6 mo - 1 yr) or when trouble is suspected:*

Frequency-Weighting Test.

- a. Set 1986: 1 kHz, 114 dB, CALIBRATED SPL.
- b. Set instrument under test: LEVEL RANGE to measure 114 dB high on scale, FAST or SLOW response, A WEIGHTING.
- c. Adjust sensitivity of instrument under test to level of 114 dB (apply appropriate correction from Table A that follows these instructions).
- d. Select other five FREQUENCY settings on 1986, and note indications; apply appropriate correction each time. Compare levels to weighting tolerances in Table 2-1 of manual.
- e. Repeat step a for B and C weighting, if desired, and check tolerance in Tables 2-2 and 2-3.

Linearity and Tracking Tests.

- a. Set 1986: 1 kHz, 114 dB, CALIBRATED SPL.
- b. Set instrument under test: LEVEL RANGE to measure 114 dB high on scale, FAST response, A WEIGHTING.
- c. Note reference reading on instrument under test.
- d. *Indicator Linearity.* Decrease 1986 LEVEL in 10-dB steps, and note if reading on instrument under test responds in corresponding 10-dB steps. Tolerances are listed in Tables 2-4, 2-5 of manual.
- e. *LEVEL RANGE Control (Attenuator) Tracking Accuracy.* Repeat steps a through c; decrease LEVEL RANGE control on instrument under test in 10-dB (or 20-dB) steps, and make corresponding changes with 1986 LEVEL control. Readings should agree, within tolerances listed in Table 2-6 of manual.

Dynamic-Characteristics Test.

- a. Set instrument under test: LEVEL RANGE as desired, FAST response, A WEIGHTING.
- b. On 1986: set VARIABLE SPL to **set fast/slow** (reference), any FREQUENCY (1 kHz is automatically generated for this test), adjust LEVEL and SPL ADJUST to set reference level at 4 dB below upper limit of indicator.
- c. On 1986, set VARIABLE SPL to **fast** to produce 200-ms tone bursts to test FAST indicator response. Note maximum reading. (HINT: To check maximum meter response, it may be helpful to slide a card parallel with needle over meter scale to point at which MAXIMUM excursion of needle just becomes visible.)
- d. Set instrument under test to SLOW response. On 1986, set VARIABLE SPL to **slow** to produce 500-ms tone bursts to test SLOW response. Note maximum reading.
- e. Compare both FAST and SLOW maximum readings with tolerances in Table 2-7 of manual.

RMS-Accuracy (Crest-Factor-Capacity) Test.

- a. Set instrument under test: LEVEL RANGE as desired (100-dB maximum upper limit), FAST or SLOW response, C or FLAT WEIGHTING.
- b. On 1986: set VARIABLE SPL to **set crest fctr** (reference), any FREQUENCY (2 kHz automatically generated), adjust LEVEL and SPL ADJUST controls to set reference level at 2 dB below upper limit of indicator.
- c. On 1986, set VARIABLE SPL to **crest factor** to produce a tone-burst signal with crest factor of 3; this tests rms accuracy of instrument under test. Note change in reading.
- d. Compare change in reading with tolerances in Table 2-8 of manual.

MICROPHONE CORRECTIONS.

The following table (Table A) lists corrections, for various microphones, that are to be applied to the reading of an instrument being calibrated by the 1986; these corrections are only applicable at the high frequencies (1 kHz, 2 kHz and 4 kHz) of the 1986. The corrections listed for microphones designed for free-field response (either perpendicular or random incidence) incorporate pressure-to-free-field, high-frequency and

microphone-volume corrections; corrections listed for microphones designed for pressure response incorporate high-frequency and microphone-volume corrections. These corrections are discussed in para 2.11 and 2.12, and must be applied when either a *Sensitivity Test* or a *Frequency-Weighting Test* is performed. The applicable correction (in dB) is to be added to the reading of the instrument under test *before* comparing it with the calibrated output of the 1986 (shown on its panel by the position of the LEVEL switch).

Table A
MICROPHONE CORRECTIONS*

Microphone Mfr. & Type	GR Adaptor Used	1-kHz Correction (dB)	2-kHz Correction (dB)	4-kHz Correction (dB)
Random-Incidence-Response Microphones:				
GR 1961-9610 or -9601 (1-in. electret)	none	0.0	0.1	1.2
GR 1962-9610 or -9601 (1/2-in. electret)	1987-7061	0.0	0.1	1.0
GR 1971 (1-in. ceramic)	none	0.0	0.1	1.2
GR 1983 Sound-Level Meter (1/2-in. ceramic)	1987-7061	0.0	0.2	1.1
GR 1954 Noise Dosimeter (3/8-in. ceramic)	1987-7076 & 1987-7095	0.0	0.1	0.5
Shure Bros. Model 98108 (1-1/8-in. ceramic)	1987-7066	0.0	---	---
<hr style="border-top: 1px dashed black;"/>				
Perpendicular-Incidence — Response Microphones:				
GR 1961-9611 or -9602 (1-in. electret)	none	0.3	1.0	3.5
GR 1962-9611 or -9602 (1/2-in. electret)	1987-7061	0.1	0.4	1.8
†B & K 4131/45 (1-in. cond)	5855-6920 (O-ring)	0.3	1.2	3.5
B & K 4133/65 (1/2-in. cond)	1987-2050	0.0	0.3	1.0
B & K 4135 (1/4-in. condenser)	1987-2060	0.0	0.0	-0.2
<hr style="border-top: 1px dashed black;"/>				
Pressure-Response Microphones (GRID ON):				
Western Electric 640AA, B & K 4160 (1-in. condenser)	none	0.0	-0.2	-0.5
Tokyo Riko MR103 (1-in. condenser)	none	0.0	-0.2	-0.5
†B & K 4132 (1-in. condenser)	5855-6920 (O-ring)	0.0	0.2	0.6
B & K 4134 (1/2-in. condenser)	1987-2050	0.0	0.0	0.2
B & K 4136 (1/4-in. condenser)	1987-2060	0.0	0.0	-0.4

* Measurement Conditions: Atmospheric Pressure, 760 mm (30 in.) of Hg.
Temperature, +20°C (68°F).

† Additional microphone-volume corrections required at lower frequencies; refer to Table 2-13.

Introduction – Section 1

1.1 PURPOSE

The GR 1986 Omnicall is a comprehensive sound-level calibrator capable of testing all the basic characteristics of a sound-measuring instrument with the exception of directivity. It is intended for use, in field or laboratory calibration, on a wide variety of sound-level meters, analyzers, or sound-measuring systems that use microphones adaptable to its cavity.

1.2 DESCRIPTION.

The GR 1986 Omnicall produces 6 steady-tone octave frequencies in the range of 125 Hz to 4000 Hz, at 5 calibrated sound-pressure levels (SPL) that increase in 10-dB steps from 74 dB to 114 dB. In addition, it generates various tone bursts to verify the dynamic characteristics and rms accuracy of a sound-level-meter detector and indicator. The cavity of the 1986 will accommodate all GR 1-in. electret-condenser microphones, GR 1-in. ceramic microphones, the Western Electric 640AA (or equivalent) microphone, and the Tokyo Riko MR103 microphone. The 1986 is also supplied with an adaptor that mates with GR 1/2-in. electret-condenser microphones. An optional adaptor set is available to accommodate the 3/8-in. microphone used on the GR 1954 Noise Dosimeter, the B & K 1-in., 1/2-in., and 1/4-in. microphones, and the Shure Brother's Model 98108 1-1/8-in. microphone.

1.3 CONTROLS, INDICATORS AND CONNECTORS.

Figure 1-1 illustrates controls, indicators and connectors on the GR 1986; Table 1-1 describes these items.

1.4. ACCESSORIES.

Model GR 1986-3000 signifies the Omnicall Sound-Level Calibrator only, with no accessories. Model GR 1986-9700 signifies the instrument and some included accessories that are delineated in Table 1-2; Figure 1-2 illustrates these accessories (the optional carrying case shown is not included in the GR 1986-9700 package). Figure 1-3 illustrates the optional GR 1987-9600 Microphone Adaptor Set, an accessory available by order from GenRad; the adaptors in this set are described in Table 1-3.

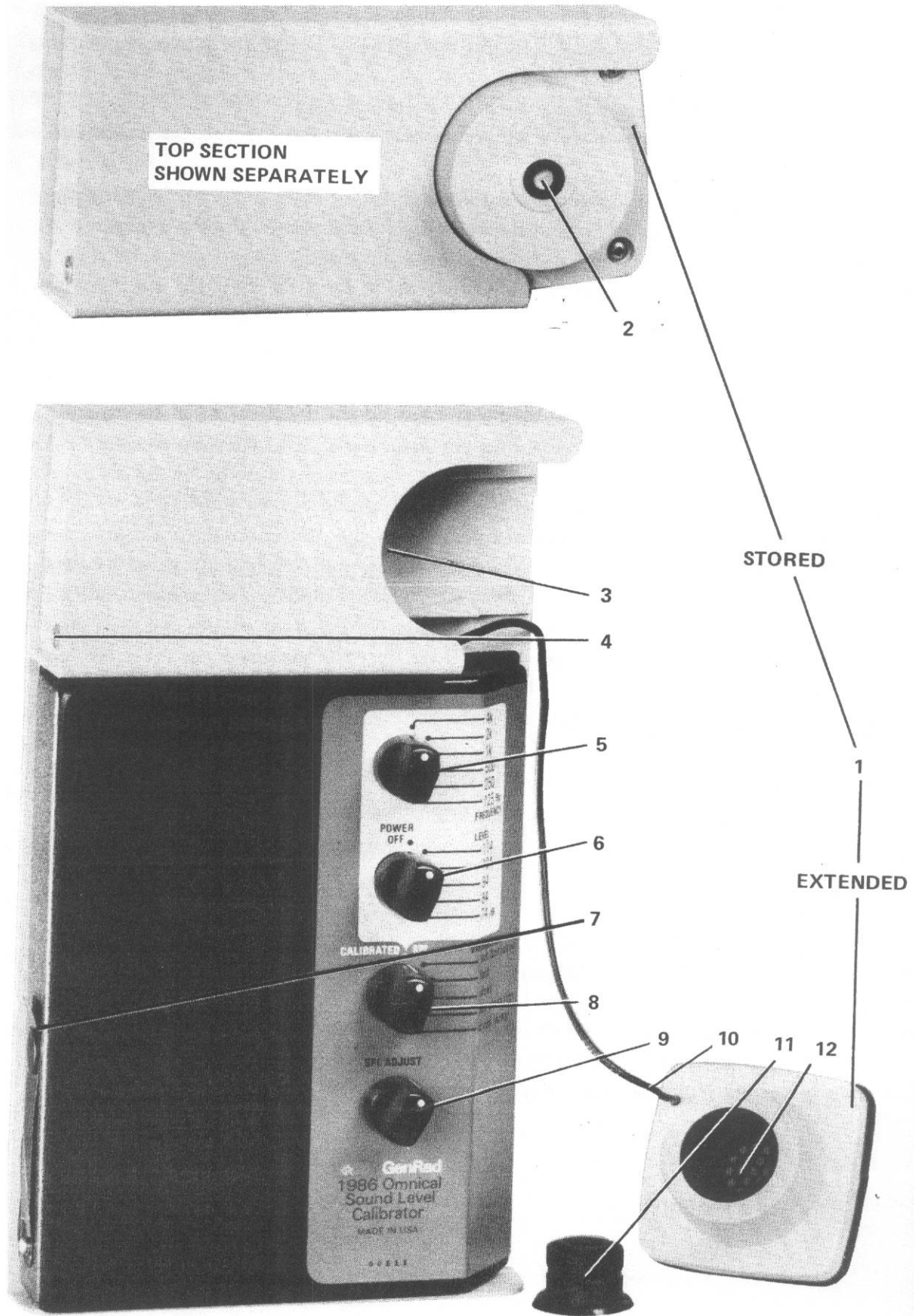

Figure 1-1. Controls, indicators and connectors. (NOTE: 1986 shown upright for illustrative purpose only; proper position is resting on feet.)

Table 1-1
CONTROLS, INDICATORS AND CONNECTORS

Fig. 1-1

Ref.	Name	Description	Position(s)	Function
1	Transducer Assembly	Extendable assembly containing electro-magnetic transducer.	Stored or extended	Provides acoustical output to calibrate a sound-measuring instrument.
2	Desiccant Window	4-1/2-cm (1-3/4-in.) circular window.		Allows observation of desiccant indicator.
3	Storage Compartment	Opening in top section; guides and retaining clips on housing position and secure transducer assembly.		Allows storage of extension cable (coiled) and transducer assembly.
4	Battery Compartment	Recess in housing; access obtained via hinged cover.		Contains 9-V alkaline battery that provides instrument power.
5	FREQUENCY	6-position rotary switch.	4k, 2k, 1k, 500, 250, 125 (Hz)	Selects frequency of calibrated output level in CALIBRATED SPL mode; disabled in other five VARIABLE SPL modes.
6	LEVEL	6-position rotary switch.	POWER OFF 114, 104, 94, 84, 74 (dB)	Disconnects instrument from internal battery source. Selects calibrated output level re 20 μ Pa in CALIBRATED SPL mode; selects nominal output in other 5 VARIABLE SPL modes that is adjustable with vernier SPL ADJUST control.
7	AC OUTPUT	Miniature phone-jack, .097-in. diameter, Switchcraft Type TR-2A. Accepts Switchcraft Type 850 miniature phone plug.		Provides nominal output of 230 mV for 114-dB SPL.

Table 1-1 (Cont.)

Fig. 1-1 Ref.	Name	Description	Position(s)	Function
8	VARIABLE SPL	6-position rotary switch.	CALI- BRATED SPL	Calibrator generates continuous output deter- mined by FREQUENCY and LEVEL controls.
			set fast/slow	Calibrator generates con- tinuous 1-kHz tone at LEVEL selected (adjust- able with SPL ADJUST); used to set reference for FAST and SLOW tone- burst tests.
			fast	Calibrator generates con- tinuous series of 1-kHz tone bursts; each burst has 200-ms duration every 2 s.
			slow	Calibrator generates con- tinuous series of 1-kHz tone bursts; each burst has 500-ms duration every 10 s.
			set crest fctr	Calibrator generates con- tinuous 2-kHz tone at LEVEL selected (adjust- able with SPL ADJUST); used to set reference for crest-factor tests.
			crest factor	Calibrator generates continuous series of 2-kHz tone bursts with crest factor of "times 3."
9	SPL ADJUST	1-turn continuous potentiometer.		When used in conjunction with LEVEL control, allows continuously vari- able level from 72 dB to 118 dB in fast or slow mode, or from 75 dB to 111 dB in crest factor mode.
10	Extension Cable	61-cm (2-ft.) cable.		Allows extension of trans- ducer assembly to instru- ment being calibrated.
11	Adaptor (supplied with GR 1986- 9700)	1/2-in. microphone adaptor.		Allows tight pressure coupling of transducer to 1/2-in. microphone.
12	Cavity	1-in. microphone cavity.		Allows tight pressure coupling of transducer to 1-in. microphone.

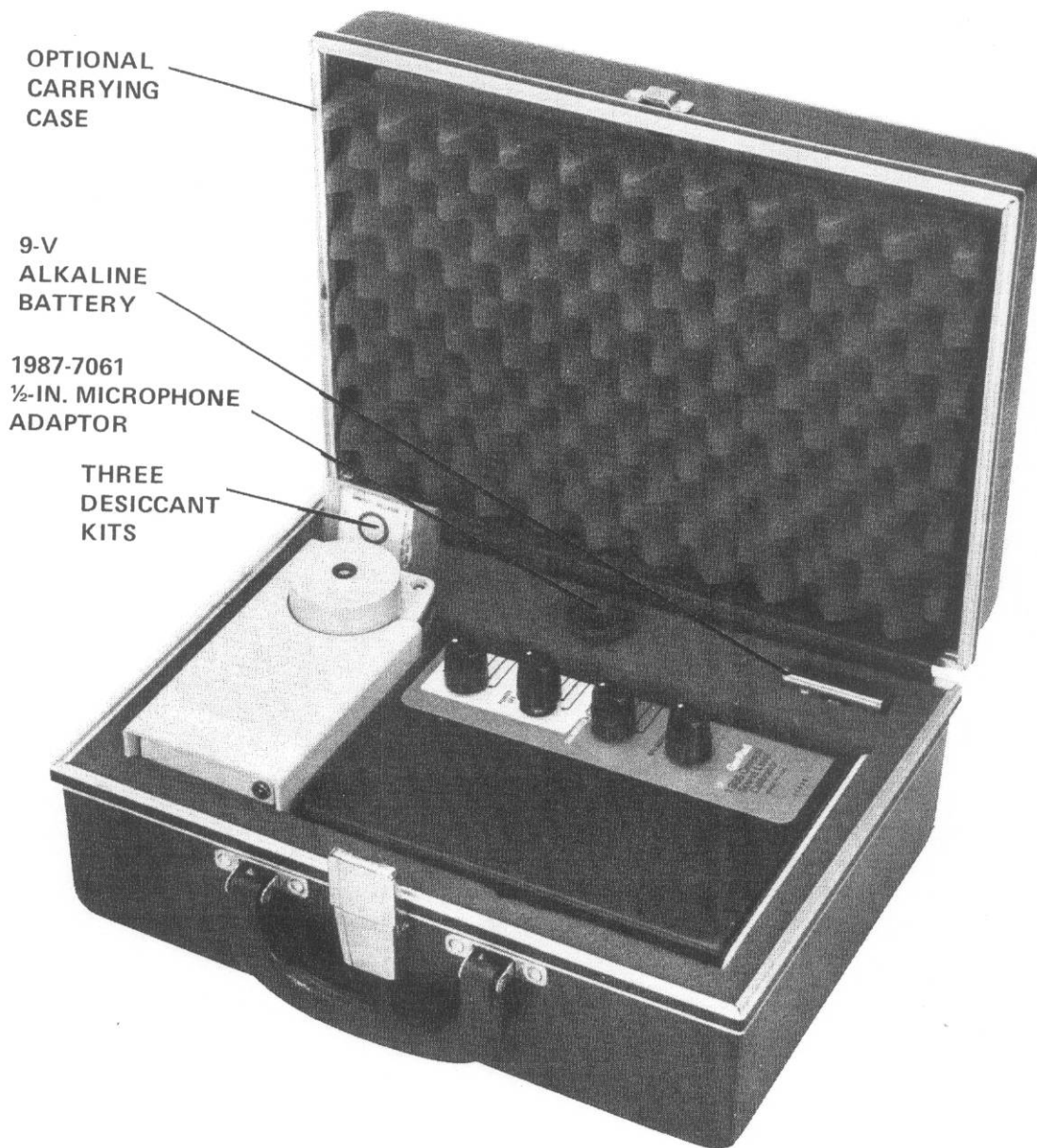

Figure 1-2. GR 1986-9700 package (exceptions: instruction manual not shown and optional carrying case is not part of package).

Table 1-2
GR 1986-9700 PACKAGE

Description	GR Part Number
Omnicol Sound-Level Calibrator, instrument only	1986-3000
Adaptor for 1/2-in. Microphone	1987-7061
Battery, 9-V Alkaline	8410-3400
3 Desiccant Kits (2 dessicants and 1 indicator per kit)	5863-3002
Instruction Manual	1986-0100

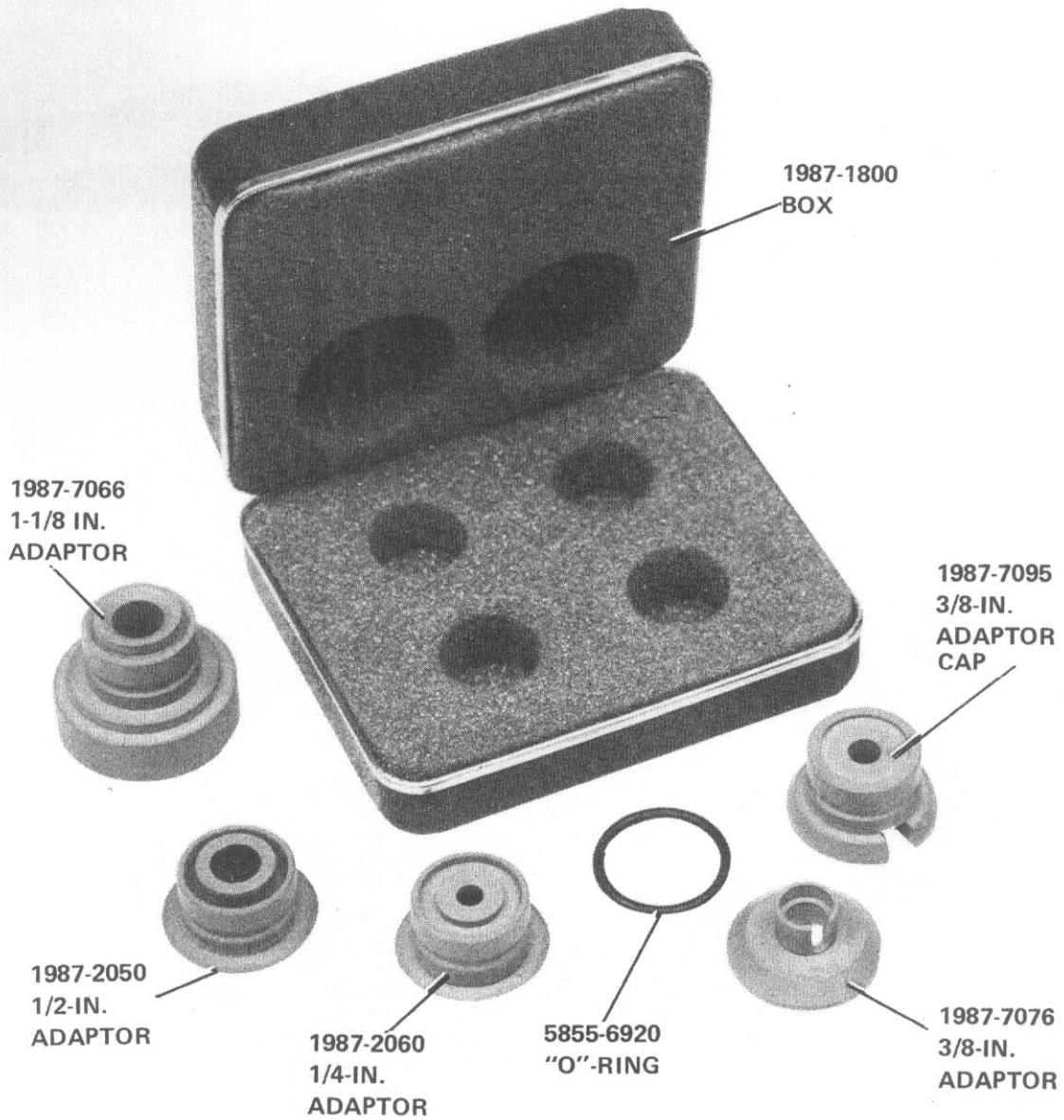

Figure 1-3. GR 1987-9600 Microphone Adaptor Set.

Table 1-3
ACCESSORIES AVAILABLE

Description	GR Part Number
Carrying Case for 1986-3000	1986-9600
Microphone Adaptor Set, consists of:	1987-9600
Box (for adaptors below)	1987-1800
GR 1954 Microphone Adaptor	1987-7076
GR 1954 Microphone Adaptor Cap	1987-7095
"O"-Ring (for B & K Type 4131/32 1-in. microphone)	5855-6920
Adaptor (for B & K Type 4133/34 1/2-in. microphone)	1987-2050
Adaptor (for B & K Type 4135/36 1/4-in. microphone)	1987-2060
Adaptor (for Shure Bros. Model 98108 1-1/8-in. microphone)	1987-7066

Operation – Section 2

2.1 UNPACKING AND INSPECTION.

If the shipping carton is damaged, ask that the carrier's agent be present when the instrument is unpacked. Inspect the instrument for damage (scratches, dents, broken parts, etc). If the instrument is damaged or fails to meet specifications, notify the carrier and the nearest GenRad field office (see list at back of this manual). Retain the shipping carton and the padding material for the carrier's inspection.

The battery must be installed in the 1986 to make it operable; para 2.2 gives the procedure for battery installation.

A small circular window on the transducer housing of the 1986 provides observation of a desiccant indicator. If half or more of this indicator has turned from pale blue to pink, the 2 desiccants, which are used for moisture control, need replacement. Refer to para 2.5 for replacement procedures.

2.2 BATTERY INSTALLATION.

The 1986 is shipped with the battery removed. A 9-V alkaline battery is included with the accessories, and this is the only type of battery recommended for use that will provide an optimum operating life.* A new alkaline battery will provide approximately 8 h of continuous operation. To install the battery, proceed as follows:

- a. Orient the 1986 so that the battery compartment is accessible (see Figure 2-1).
- b. Loosen the captive thumbscrew that secures the hinged battery-compartment door, grasp the knurled head of the screw, and pull the door open.
- c. Before inserting the battery, observe its polarity with respect to the battery outline shown inside the compartment (indicated also in Figure 2-1).
- d. Push the bottom of the battery against the foam to compress it, and simultaneously push the other end of the battery (terminal end) into the compartment such that it is firmly seated and makes contact with the spring-metal contacts.
- e. Close the battery-compartment door and tighten the thumbscrew.

2.3 BATTERY CHECK.

If the battery voltage is not adequate, there will either be no acoustic output from the calibrator, or the output will cut out at higher dB levels after being on for a short while.

NOTE

If the output does cut out, it can appear to be the result of a faulty LEVEL switch, when in actuality it is the result of a low battery.

To check for sufficient battery voltage, proceed as follows:

- a. Set: FREQUENCY 1 kHz
LEVEL 114 dB
VARIABLE SPL CALIBRATED SPL

* GenRad recommends Mallory MN 1604 or Eveready 522.

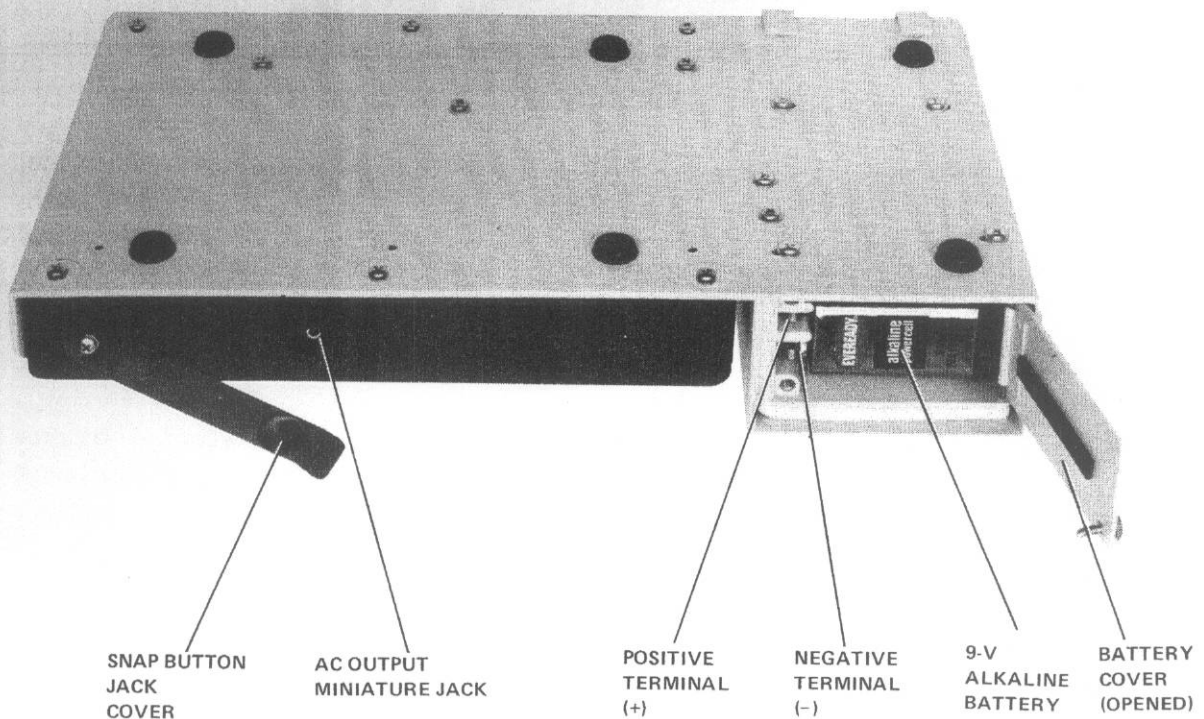

Figure 2-1. Battery compartment and AC OUTPUT jack. (NOTE: Instrument shown in this position for illustrative purpose only; proper position is resting on feet.)

b. If the battery is up to operating voltage, a constant tone will be heard. If the tone cuts out or is nonexistent, replace the battery (refer to para 2.2).

2.4 BATTERY REMOVAL.

CAUTION

If the 1986 is to be out of use for a period of 6 months or more, the battery should be removed to prevent corrosion at its terminals.

To remove the battery for replacement or storage, proceed as follows:

- a. Orient the 1986 to make the battery compartment accessible (see Figure 2-1).
- b. Loosen the captive thumbscrew that secures the hinged battery-compartment door, grasp the knurled head of the screw, and pull the door open.
- c. Place a finger, or small tool such as a screwdriver, on the terminal end of the battery, and push it to compress the foam at the other end; with the same finger or tool, pull up slightly until the battery pops out.

2.5 DESICCANT REPLACEMENT.

The transducer assembly of the 1986 contains 2 disk-shaped desiccant papers (refer to Figure 2-2), in order to keep the interior humidity low relative to any high external



Figure 2-2. Transducer assembly disassembled.

humidity. The desiccants are used to minimize the effects of humidity upon the transducer, which produces a more stable output when dry.

Each desiccant has a diameter of about 4.4 cm (1-3/4 in.), and one is mounted on top of the other inside the transducer housing. A desiccant-indicator paper is mounted on top of the desiccant papers, where it is visible through the small circular window on the transducer housing. This desiccant indicator is divided into 2 sections that are visible through the window. When the maximum amount of moisture has been absorbed by the 2 desiccants underneath it, one side of the indicator will turn from pale blue to pink, while the other side remains pale blue. Such an indication means that both the indicator and 2 papers should be replaced. Three accessory desiccant kits (P/N 5863-3002), in air-tight packages, are supplied with the instrument; each kit contains 1 indicator and 2 papers.

The desiccant papers are made from a silicon-gel-activated absorbent. The papers and indicator can be dried out by baking them at 148°C (300° F) for 5 to 10 min. To replace or remove the desiccants, proceed as follows (refer to Figure 2-2):

a. Remove the 4 Phillips-head screws from the top of the transducer housing, and then lift off the top.

b. Replace the 2 desiccant papers and the indicator with ones from a spare kit (P/N 5863-3002). The indicator should be positioned such that the round indicator portion is visible through the window when the top cover is reinstalled. The bottom part of the indicator paper can be bent down over the edge of the transducer, which helps to prevent the desiccant from sliding.

c. Position the cover, making sure it seats properly in the gasket, and tighten the 4 screws. Make sure again that the gasket has been properly seated; it can be properly seated by running a fingernail around its edge.

2.6 TRANSDUCER ASSEMBLY.

The transducer assembly, which is mounted on a microphone under test, should be placed in its storage compartment when not being used. It is held in position by 2 retaining fingers that clamp around its base.

2.6.1 Transducer Removal.

a. To remove the transducer assembly from the 1986, grasp it at the top and pull it straight out. The cable that connects the transducer assembly to the main instrument will pull out as the transducer is removed.

b. The transducer can now be mounted on the microphone of the sound-measuring instrument under test, provided it is fitted with the proper adaptor as described in para 2.7.

2.6.2 Transducer Storage.

a. Before replacing the transducer in its storage compartment, loop the loose cable into a small coil and insert it into the compartment ahead of the transducer.

b. Slide the transducer assembly into the compartment such that it is held by the 2 retaining fingers. These fingers will spread and then clamp securely around the transducer's base as it is pushed into place.

CAUTION

When storing the transducer, be careful not to pinch the extension cable in the retaining fingers.

2.7 MICROPHONE ADAPTORS.

2.7.1 General.

The transducer cavity of the 1986 will accommodate the following 1-in. microphones: the GR 1961 Electret Condenser, the GR 1971 Ceramic, the Western Electric 640AA, and the Tokyo Riko MR103. Adaptors must be used for other-sized microphones, and for the B & K 1-in. microphone.

The 1/2-in. microphone adaptor, P/N 1987-7061, is an accessory included with the 1986 Omnical. It must be inserted into the cavity of the transducer assembly when calibration is being performed on an instrument with a GR 1/2-in. electret-condenser microphone. Adaptors for microphones other than GR 1/2-in. and 1-in. microphones are available in an accessory kit, P/N 1987-9600, which is described below.

The GR 1987-7061 Microphone Adaptor is inserted by gently pushing it into the cavity until the 3 detents inside the cavity fall into the groove around the outside of the adaptor. Make sure it is firmly seated. To remove the adaptor, grasp its outer flange that protrudes out of the cavity, and pull it out.

NOTE

It is possible to replace the transducer in its storage compartment with the 1/2-in. adaptor still inserted.

2.7.2 Microphone Adaptor Set.

The GR 1987-9600 Microphone Adaptor Set is an optional accessory available by order from GenRad. It includes 6 microphone adaptors that are necessary to accommodate various microphones on instruments under test. The base of each adaptor is marked with its appropriate part number; Figure 1-3 and Table 1-3 illustrate and describe the adaptors in this set.

The 6 adaptors in this set are inserted in the transducer cavity as described below:

- GR 1987-2050 Microphone Adaptor for B & K Type 4133/34 1/2-in. microphone: insert in same manner as 1987-7061 adaptor.

NOTE

This adaptor appears similar to the GR 1987-7061 Adaptor except for an O-ring and minor dimension differences inside the B & K adaptor. They are *not* interchangeable.

- GR 1987-2060 Microphone Adaptor for B & K Type 4135/36 1/4-in. microphone: insert in same manner as 1987-7061 adaptor.
- GR 1987-7066 Microphone Adaptor for Shure Bros. Model 98108 1-1/8-in. microphone: insert in same manner as 1987-7061 adaptor.
- GR 5855-6920 O-ring for B & K Type 4131/32 1-in. microphone: place it in the cavity and, with the index finger, work it into the groove all the way around the inside of the cavity. (To remove the O-ring, slide a small screwdriver down 1 of the 3 grooves in the cavity until it is behind the O-ring, and then pry it out.)
- GR 1987-7076 Microphone Adaptor and GR 1987-7095 Adaptor Cap for 3/8-in. microphone (used on GR 1954 Noise Dosimeter) — proceed as follows:
 - a. Set the microphone cap (P/N 1987-7095) flat side down on a bench or table.
 - b. Insert the 3/8-in. microphone into the cap with its diaphragm side up. The microphone cable should slide into the groove on the side of the cap as the microphone is inserted.
 - c. Place the GR 1987-7076 Microphone Adaptor over the cap such that the groove in the side of the adaptor fits over the cable from the microphone.
 - d. Insert the microphone-cap-adaptor assembly into the 1986 transducer cavity in the same manner as the adaptor described in para 2.6.1 was installed.

CAUTION

Do not set the transducer on a surface subject to vibration when calibration is performed. This can introduce an ambient level significant enough to cause a false calibration indication, especially at the lower levels of the 1986.

2.8 OPERATIONAL CHECK.

The following suggested procedure provides a quick, audible check to determine if the 1986 is functioning properly.

- a. Set: FREQUENCY 1 kHz
LEVEL 114 dB
VARIABLE SPL CALIBRATED SPL

b. A constant 1-kHz tone should be audible from the calibrator; if the tone cuts out or is nonexistent, the battery may need replacement.

WARNING

Do not place the transducer assembly near the ear; its higher level output signals could damage hearing ability.

c. Switch the FREQUENCY control through all its positions. The change in frequency should be clearly evident.

d. Set the 1986 FREQUENCY to 1 kHz, and then switch the LEVEL control through all its positions from 114 dB to 74 dB. The reduction in sound level from 1 position to the next should be clearly evident. Notice that if the SPL ADJUST control is varied it has no effect on the output level.

e. Set: LEVEL 114 dB
VARIABLE SPL **set fast/slow**

f. Vary the SPL ADJUST potentiometer; an increase in level should be noticed in the cw direction, and a decrease in level in the ccw direction. This mode is used to set the reference on a sound-level meter for fast and slow-response tests.

g. Notice that if the FREQUENCY switch is changed it does not change the frequency of the output signal; this is fixed at 1 kHz for the **set fast/slow** mode. Changing the LEVEL switch, however, does change the level; notice that the SPL ADJUST provides level variation for each position of the LEVEL switch (this is true for every position of the VARIABLE SPL control except CALIBRATED SPL).

h. Return the LEVEL switch to 114 dB, and set the VARIABLE SPL switch to **fast**. Repeated 1,000-Hz tone bursts should be audible. These tone bursts have 200-ms pulse durations and are used for measuring the FAST rise response of a sound-level meter. The bursts are repeated every 2 s; i.e., there is a 0.2-s pulse duration, followed by 1.8 s where the pulse is reduced in level by 20 dB.

i. Set the VARIABLE SPL switch to **slow**. Repeated 1000-Hz tone bursts should be audible. These tone bursts have 500-ms pulse durations and are used for measuring the SLOW rise response of a sound-level meter. The bursts are repeated every 10 s; i.e., there is a 0.5-s pulse duration, followed by 9.5 s where the pulse is reduced in level by 20 dB.

j. Set: LEVEL 104 dB
VARIABLE SPL **set crest fctr.**

k. Vary the SPL ADJUST as before; an increase in level should be noticed in the cw direction, and decrease in level in the ccw direction. This mode is used to set the reference on a sound-level meter for crest-factor tests.

l. Notice that changing the FREQUENCY switch does not change the frequency of the output signal; this is fixed at 2 kHz. Changing the LEVEL switch does change the level (with the exception of the 114-dB position, which is nonfunctional); the level variation possible with the SPL ADJUST control should be checked for each position.

m. Return the LEVEL switch to the 104-dB position and set the VARIABLE SPL switch to the **crest factor** position. Repeated 2000-Hz tone bursts should be audible. These rapid-succession tone bursts have 5.5-ms pulse durations and are used for measuring the crest-factor capacity and rms accuracy of a sound-level meter.

2.9 CALIBRATION OF SOUND-MEASURING INSTRUMENTS.

2.9.1 General.

Before a sound-level meter or analyzer is used to make a measurement or analysis, it should be checked to ensure that it is operational and conforms to applicable standards. The 1986 Omnical Sound Level Calibrator is capable of providing a wide variety of outputs to satisfy these needs. In particular, the calibration and verification tests that will be described in the following paragraphs are defined by specifications from the following standards:

ANSI* S1.4-1971

IEC R123-1961, 179-1973 and 179A-1973

IEC Consolidated Revision of Publications R123, 179 and 179A †

Section 3 contains direct excerpts from these standards for reference purposes; most of the excerpts are from the ANSI S1.4-1971 and IEC Consolidated Revision standards. The latter is pending final approval, and is expected to supersede the IEC R123-1961, 179-1973 and 179A-1973 publications upon its final issue. †

Throughout the operating procedure described in the remainder of this section, various tolerance tables are referred to when checking the characteristics of a measuring instrument. These tables are taken from the Standards, in portion or in entirety, for the convenience of the user.

There are 5 basic tests that may be performed on a sound-level meter or analyzer using the 1986. They are:

- Sensitivity
- Frequency Weighting
- Linearity and Tracking of Indicator and LEVEL RANGE Control
- Dynamic Characteristics
- RMS Accuracy (Crest-Factor Capacity)

These 5 tests are described in the following paragraphs. The procedures are intended to serve as a guide for the user of the 1986; the standards and the instruction manual for the instrument being tested should also be consulted when necessary. A condensed version of these 5 test procedures is located in the front of the manual.

NOTE

Charts on Page 6-10 (tipout) may be used to record results of following tests.

2.9.2 Sensitivity.

The 1986 can check the absolute sensitivity of a total sound-measuring instrument, including the microphone, at a specific frequency. The sensitivity of a sound-level meter or analyzer is tested by placing the transducer assembly of the calibrator, with a precisely known level, on the microphone of the instrument under test. The instrument is then adjusted to indicate the known level. For example, if the known output level from an acoustic calibrator is 114 dB re 20 μ Pa, then the instrument being checked or adjusted should also read 114 dB.

*Ref: "American National Standard Specification for Sound-Level Meters," ANSI S1.4-1971, published 1971, American National Standard Institute, Inc., 1430 Broadway, New York, N.Y. 10018.

†Superseded by IEC Sound Level Meter Standard 651; International Electrotechnical Commission, 1 Rue de Varembe, Geneva, Switzerland.

A unique feature of the 1986 is its wide range of 5 calibrated output levels at 114 dB, 104 dB, 94 dB, 84 dB and 74 dB. This wide range usually allows a sensitivity check or adjustment to be made near the level at which the measuring instrument is intended to be used.

The sensitivity of a sound-level meter or analyzer is normally checked at a reference frequency of 1 kHz. The following procedure is suggested as a means to check and adjust the sensitivity of an instrument. Figure 2-3 shows the setup for this sensitivity test with a typical sound-level meter.

CAUTION

Ambient sources of noise or vibration can cause a false calibration indication; this can be especially significant at the lower levels of the 1986.

a. The 1986 offers a choice of 5 calibrated output levels. Select the level closest to the level that is to be used for measurement by the instrument under test. Use a level of 114 dB or 94 dB if the level at which measurements will be made is not known.

b. On the instrument under test, set the LEVEL RANGE control to the lowest possible setting that allows the upper limit of its range to be above the 1986 LEVEL selected in step a. The instrument may be set to FAST or SLOW response and the weighting characteristic (FLAT, A, B or C) that is to be used for measurement.

c. Set the 1986 as follows:

FREQUENCY	1 kHz
LEVEL	as chosen in step a
VARIABLE SPL	CALIBRATED SPL



Figure 2-3. Typical calibration setup with a GR 1565-B Sound-Level Meter.

d. Place the 1986 transducer, with the correct microphone adaptor, on the microphone of the instrument under test.

e. Read the level indicated by the instrument under test, and adjust its sensitivity control to indicate the level selected in step a.

f. It may be necessary to apply corrections to the reading obtained in step e; the amount of correction is dependent upon the particular microphone being used. Microphone corrections due to pressure-to-free-field calibration differences (para 2.11) and microphone-effective-volume variations (para 2.12) are combined in the correction values listed in Table A of the Condensed Operating Instructions. Normal variations in temperature and atmospheric pressure near sea level will have negligible effect on the sound-pressure level developed by the 1986. Altitude-variation corrections are given in para 2.10 for applications where they are required.

g. An example of a microphone correction follows:

Conditions of Measurement:

FREQUENCY1 kHz

Microphone TypeGR 1962-9611

1/2-in. electret, flat perpendicular

Correction from Table A of Condensed Operating Instruction: 0.1 dB.

For this example, the sensitivity of the instrument under test is adjusted for an indication of 0.1 dB below the 1986 LEVEL selected in step a. Thus, if the 1986 LEVEL control is set to 114 dB, adjust the measuring instrument's sensitivity for a reading of 113.9 dB.

2.9.3 Frequency-Weighting Characteristics.

There are 3 frequency-weighting characteristics, any one or all of which may be included on a sound-level meter. These 3 weightings are designated A, B and C, and are illustrated graphically in Figure 2-4.

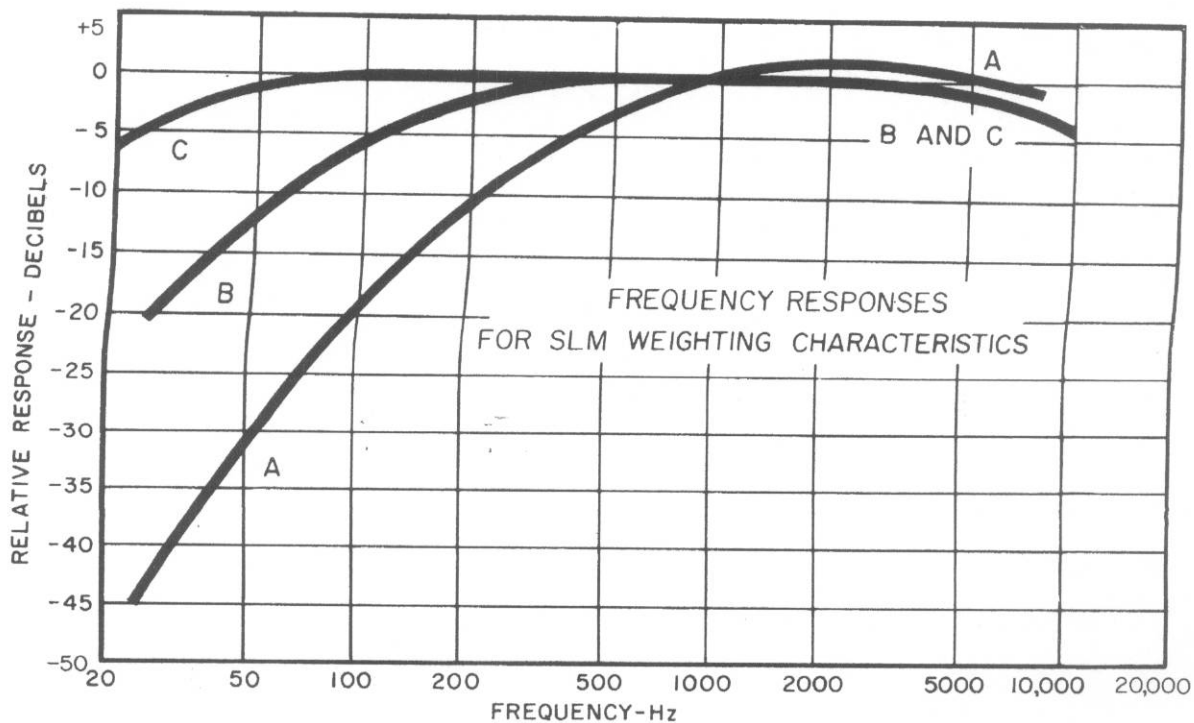

Figure 2-4. Frequency-weighting characteristics as specified in ANSI and IEC standards for sound-level meters.

The standards for sound-level meters require that the frequency characteristics for these weightings be maintained within certain tolerance limits referred to the nominal response shown in Figure 2-4. Three types of sound-level meters (Types 1, 2 and 3) are specified by the ANSI and IEC Standard, each having different tolerance limits for the weighting characteristics; the IEC Standards also specify a fourth type of meter, the Type 0 meter. Tolerances are tightest for the Type 0 instrument, and broadest for the Type 3 instrument.

The 1986 allows a frequency-weighting check of a sound-level meter at 6 frequencies from 125 Hz to 4,000 Hz. Since the responses of all 3 weightings are identical at 1 kHz (see Figure 2-4), the reference is established at this frequency; then, the response of the meter is checked at frequencies above and below the 1-kHz reference level. The following procedure is suggested as a means to check the weighting response of a sound-level meter, which should be within the required tolerance specified for its type.

a. On the instrument under test, set the LEVEL RANGE control to 120 dB full scale. If it does not have a 120-dB full-scale range, use the highest full-scale setting. The instrument may be set to FAST or SLOW response and the weighting characteristic (A, B or C) that is to be checked.

b. Set the 1986 as follows:

FREQUENCY	1 kHz
LEVEL	114 dB
VARIABLE SPL	CALIBRATED SPL

c. Adjust the sensitivity of the instrument under test for an indication that corresponds to the 114-dB level. This level is often 114 dB, but may be several tenths of a dB less, depending on the correction required for a particular microphone. Some microphones require no correction. Refer to Table A of the Condensed Operating Instructions for correction information.

d. Select, in turn, each of the other 5 FREQUENCY switch settings on the 1986, while maintaining the LEVEL switch at 114 dB. Record the 5 dB readings obtained for each of the 5 calibrator frequencies, apply microphone corrections where necessary (Table A, Condensed Operating Instructions) and then compare the 5 corrected dB-level readings with the upper and lower tolerance limits from either Table 2-1 (A-weighting test), Table 2-2 (B-weighting test), or Table 2-3 (C-weighting test).^{*} Each of the 5 corrected levels should fall within the tolerance limits given in the appropriate table in order for the instrument under test to conform to the specifications of the standards. Note, when using these 3 tables, that it is first necessary to locate in the heading the meter type and standard (ANSI or IEC) that is applicable to the instrument under test/measurement to be performed; also, the second column from the left indicates the nominal dB level, for a particular weighting and frequency, as depicted in Figure 2-4.

e. If it is desired to check the weighting response with respect to a reference level other than 114 dB, select that desired reference level on the calibrator when performing step b. Then, in step c, calibrate the sensitivity of the instrument at the desired reference level. All values listed in Tables 2-1, 2-2 and 2-3 are for a reference

^{*}The values in Tables 2-1, 2-2 and 2-3 are taken directly from the ANSI and IEC Standards. The tolerance of the 1986 itself has not been incorporated into these values, and should be taken into account when a value is at the very edge of the tolerance.

Table 2-1
TOLERANCE LIMITS FOR A WEIGHTING*

Freq. (Hz)	Nominal Level from Fig. 2-4 (dB)	ANSI and IEC+ Type 1	Tolerances (in dB) per Standard and Meter Type			
			ANSI+ Type 2	IEC+ Type 2	ANSI+ Type 3	IEC+ Type 3
125	97.9	96.9 – 98.9	95.4 – 100.4	96.4 – 99.4	94.9 – 100.9	95.9 – 99.9
250	105.4	104.4 – 106.4	102.9 – 107.9	103.9 – 106.9	102.4 – 108.4	103.4 – 107.4
500	110.8	109.8 – 111.8	108.8 – 112.8	109.3 – 112.3	107.8 – 113.8	108.8 – 112.8
1 k‡	114.0	113.0 – 115.0	112.0 – 116.0	112.5 – 115.5	111.0 – 117.0	112.0 – 116.0
2 k	115.2	114.2 – 116.2	112.2 – 118.2	113.2 – 117.2	111.2 – 119.2	112.2 – 118.2
4 k	115.0	114.0 – 116.0	110.5 – 120.5	112.0 – 118.0	109.5 – 120.5	110.0 – 120.0

* All values listed in this table are for a calibrator level set at 114 dB. If another calibrator reference level is used, the difference between that reference and 114 must be subtracted from each value in this table (see para 2.9.3e).

†Standards referred to are ANSI S1.4-1971 and/or IEC Consolidated Revision.

‡Reference frequency for initial sensitivity calibration of instrument under test.

Table 2-2
TOLERANCE LIMITS FOR B WEIGHTING*

Freq. (Hz)	Nominal Level from Fig. 2-4 (dB)	ANSI and IEC+ Type 1	Tolerances (in dB) per Standard and Meter Type			
			ANSI+ Type 2	IEC+ Type 2	ANSI+ Type 3	IEC+ Type 3
125	109.8	108.8 – 110.8	107.8 – 111.8	108.3 – 111.3	107.3 – 112.3	107.8 – 111.8
250	112.7	111.7 – 113.7	111.2 – 114.2	111.2 – 114.2	110.2 – 115.2	110.7 – 114.7
500	113.7	112.7 – 114.7	112.2 – 115.2	112.2 – 115.2	111.2 – 116.2	111.7 – 115.7
1 k‡	114.0	113.0 – 115.0	112.0 – 116.0	112.5 – 115.5	111.0 – 117.0	112.0 – 116.0
2 k	113.9	112.9 – 114.9	110.9 – 116.9	111.9 – 115.9	109.9 – 117.9	110.9 – 116.9
4 k	113.3	112.3 – 114.3	108.8 – 118.8	110.3 – 116.3	107.8 – 118.8	108.3 – 118.3

* All values listed in this table are for a calibrator level set at 114 dB. If another calibrator reference level is used, the difference between that reference and 114 must be subtracted from each value in this table (see para 2.9.3e).

†Standards referred to are ANSI S1.4-1971 and/or IEC Consolidated Revision.

‡Reference frequency for initial sensitivity calibration of instrument under test.

Table 2-3
TOLERANCE LIMITS FOR C WEIGHTING*

Freq. (Hz)	Nominal Level from Fig. 2-4 (dB)	ANSI and IEC+ Type 1	Tolerances (in dB) per Standard and Meter Type			
			ANSI+ Type 2	IEC+ Type 2	ANSI+ Type 3	IEC+ Type 3
125	113.8	112.8 – 114.8	112.8 – 114.8	112.3 – 115.3	111.8 – 115.8	111.8 – 115.8
250	114.0	113.0 – 115.0	113.0 – 115.0	112.5 – 115.5	112.0 – 116.0	112.0 – 116.0
500	114.0	113.0 – 115.0	113.0 – 115.0	112.5 – 115.5	112.0 – 116.0	112.0 – 116.0
1 k‡	114.0	113.0 – 115.0	112.5 – 115.5	112.5 – 115.5	111.5 – 116.5	112.0 – 116.0
2 k	113.8	112.8 – 114.8	111.3 – 116.3	111.8 – 115.8	110.3 – 117.3	110.8 – 116.8
4 k	113.2	112.2 – 114.2	109.2 – 118.2	110.2 – 116.2	108.2 – 118.2	108.2 – 118.2

* All values listed in this table are for a calibrator level set at 114 dB. If another calibrator reference level is used, the difference between that reference and 114 must be subtracted from each value in this table (see para 2.9.3e).

†Standards referred to are ANSI S1.4-1971 and/or IEC Consolidated Revision.

‡Reference frequency for initial sensitivity calibration of instrument under test.

level of 114 dB; thus, when using 1 of these tables in step d, the difference between 114 dB and the desired reference level must be subtracted from each value in the table that is used. For example, if a reference level of 104 dB is used instead of 114 dB, then 10 dB must be subtracted from each value of the appropriate table.

f. Return the 1986 FREQUENCY switch setting to 1 kHz. Select any other weighting that is desired to be checked on the instrument under test, and repeat steps c, d and e.

2.9.4 Linearity and Tracking.

Indicator-linearity errors can occur within a particular level range on a sound-measuring instrument, if the meter and/or digital display don't track accurately across the total span of that range. LEVEL-RANGE-control errors can result if an instrument does not track accurately as it is changed from one LEVEL RANGE to another. The tolerances for these 2 different errors are specified independently in the ANSI standard; in the IEC standard, tolerances are specified in one case for an overall linearity that includes both the indicator and the LEVEL RANGE control, and in another case for the LEVEL RANGE control separately. The 3 tests below describe the following checks for a sound-measuring instrument:

- Indicator linearity per ANSI specifications.
- Overall indicator and LEVEL-RANGE-control linearity per IEC specifications.
- LEVEL-RANGE-control accuracy per ANSI and IEC specifications.

Indicator. The indicator of an instrument can be a meter or digital display, and in many cases an instrument includes both of these. Indicator-linearity tolerances specify the accuracy of the instrument's detector-indicator. The multilevels of the 1986 allow this accuracy to be checked in 10-dB steps. The 1986 can perform an indicator-linearity test in the level range from 72 dB to 118 dB (the SPL ADJUST control allows the output to be decreased to 72 dB when the LEVEL switch is set to 74 dB, and increased to 118 dB for a setting of 114 dB). It should be noted that, at the lower sound-pressure levels, an error can be introduced if the noise level in the test area is high.

ANSI Standard S1.4-1971 specifies indicator-linearity tolerances with respect to a full-scale reference reading. Then, as the level of the 1986 is decreased in 10-dB steps from this full-scale reference level, the indicator of the instrument under test must show corresponding 10-dB changes, within the tolerances specified by the standard. The procedure follows.

a. On the instrument under test, select a full-scale range between 80 dB and 120 dB; use the highest range possible to minimize interference from ambient noise. The instrument may be set to FAST or SLOW response and FLAT, C or A weighting.

b. Set the 1986 as follows:

FREQUENCY any setting (1 kHz is generated whenever the VARIABLE SPL control is in set fast/slow as selected below).

LEVEL level that corresponds to 6 dB below the upper limit of the range selected on the instrument under test.

VARIABLE SPL set fast/slow*

c. Set the SPL ADJUST control on the 1986 for a reference indication at the upper limit of the LEVEL RANGE setting on the instrument under test.

d. Reduce the LEVEL on the 1986 in 10-dB steps. The reading on the instrument under test must drop correspondingly in 10-dB steps, within the tolerances indicated in Table 2-4 for the particular type of sound-level meter being tested.

Combined Indicator and LEVEL RANGE Control. The following test, specified by the IEC Consolidated Revision Standard, addresses a linearity check differently than the preceding ANSI test. This test is an overall check of an instrument's linearity, including both the indicator and the LEVEL RANGE control. Also, in this test tolerances are referred to a reference level other than the full-scale reading of the previous test. The procedure follows.

a. On the instrument under test, set the LEVEL RANGE control to the reference range;† if the reference range is not known, choose the 100-dB full-scale range. The instrument may be set to FAST or SLOW response and FLAT, C or A weighting.

b. Set the 1986 as follows:

FREQUENCY 1 kHz (or other if desired)
 LEVEL 94 dB♦
 VARIABLE SPL CALIBRATED SPL

Table 2-4

TOLERANCES FOR INDICATOR LINEARITY**

Meter Reading on Instrument Under Test	Type 1 Meter Tolerance ±(0.2 dB + 2% dB down from full scale)	Type 2 Meter Tolerance ±(0.2 dB + 3% dB down from full scale)	Type 3 Meter Tolerance ±(0.4 dB + 6% dB down from full scale)
-10 dB down from full scale	±0.4	±0.5	±1.0
-20 dB down from full scale	±0.6	±0.8	±1.6
-30 dB down from full scale	±0.8	±1.1	±2.2
-40 dB down from full scale	±1.0	±1.4	±2.8

**Taken from ANSI Standard S1.4-1971.

*It should be noted that there is a discrepancy between the setting listed here and the setting in the Condensed Operating Instructions. This para deals exclusively with ANSI specifications, where full scale is used as a reference and the 1986 must be set to set fast/slow to obtain a full-scale adjustment.

†The reference range is a range specified by the manufacturer for calibration purposes.

♦The IEC Consolidated Revision recommends 94 dB as a reference sound-pressure level.

c. Adjust the sensitivity of the instrument under test for an indication of 94.0 dB.
 d. Decrease the LEVEL control on the 1986 in 10-dB steps. The reading on the instrument under test must decrease correspondingly in 10-dB steps, within the tolerances indicated in Table 2-5 for the particular type of sound-level meter being tested.

e. On the instrument under test, set the LEVEL RANGE control to another range (higher or lower); on the 1986, set the LEVEL control to levels that are within the range selected on the instrument under test. The readings on the instrument under test must agree with the level selected on the 1986, within the tolerances indicated in Table 2-5.

LEVEL RANGE Control. This is a test of the error introduced when the LEVEL RANGE control is changed. The multilevels of the 1986 allow the LEVEL-RANGE-control accuracy to be checked in 10-dB steps per ANSI and IEC specifications.

In order to check the LEVEL RANGE control, a reference range is first selected. The LEVEL RANGE control on the instrument under test is then switched to another range, and the 1986 LEVEL control is varied correspondingly. Ideally, the reading of the indicator should not change as the LEVEL RANGE control and 1986 LEVEL control are varied. The tolerance limits specified by the standards for the variance of this reading differ slightly between the ANSI Standard S1.4-1971 and the forthcoming IEC Consolidated Revision; they are listed in Table 2-6. The following procedure is suggested to check the LEVEL RANGE control.

Table 2-5
 TOLERANCES FOR COMBINED INDICATOR AND CONTROL*

	Tolerance (in dB) about Reference per Meter Type			
	Type 0	Type 1	Type 2	Type 3
Tolerance Inside Primary† Range	±0.4	±0.7	±1.0	±1.5
Tolerance Outside Primary† Range	±0.6	±1.0	±1.5	±2.0

*Taken from forthcoming IEC Consolidated Revision.

†"Primary Range" is specified by the manufacturer, and usually refers to the top 15 to 20 dB of the indicator.

Table 2-6
 TOLERANCE LIMITS FOR LEVEL-RANGE CONTROL

Standard	Tolerance (in dB) about Reference per Meter Type			
	Type 0	Type 1	Type 2	Type 3
ANSI S1.4-1971	±0.5	±0.5	±0.5	±1.0
IEC Consolidated Revision (forthcoming publication)	±0.3	±0.5	±0.7	±1.0

a. On the instrument under test, set the LEVEL RANGE control to a range that includes 94 dB; the 100-dB-full-scale range is recommended. The instrument may be set to FAST or SLOW response and FLAT, C or A weighting.

b. Set the 1986 as follows:

FREQUENCY 1 kHz (or other if desired)
LEVEL 94 dB
VARIABLE SPL CALIBRATED SPL

c. Note the reading on the instrument under test.

d. Change the LEVEL RANGE control in increasing or decreasing steps, and change the 1986 LEVEL control by a corresponding number of decibels each time; e.g., if the LEVEL RANGE control on the instrument under test is increased by 10 dB, the 1986 LEVEL control should also be increased by 10 dB. The reading of the instrument under test should change by this increase or decrease of decibels, within the tolerance limits given in Table 2-6 for the appropriate Standard (ANSI or IEC).

2.9.5 Dynamic Characteristics.

All sound-level meters include either a fast-response mode or a slow-response mode, and most meters include both. The indication on an instrument, in both modes, is an rms value, but with different averaging time constants. In the fast mode, the averaging circuit has a time constant of 125 ms; in the slow mode the time constant is 1 s.

The standards are very specific in detailing how a sound-measuring instrument will be checked to verify its operation in both of these modes. A steady-state reference signal of 1 kHz must first be applied, and its level is adjusted for a reading that is 4 dB below full scale on the indicator of the instrument under test. On the 1986, this reference signal is established in the **set fast/slow** position of the VARIABLE SPL switch. Once this reference is established, the fast response of the instrument under test is checked with a continuous series of 1-kHz tone bursts, each with a 200-ms duration occurring every 2 s; the slow response is checked with a series of 1-kHz tone bursts, each with a 500-ms duration, repeated every 10 s by the 1986. During the "off-time" of the tone burst, the level falls to a value 20 dB below the burst level.

The maximum level indicated by the instrument under test when the tone burst occurs is given, with tolerances, in Table 2-7 for both the ANSI and IEC standards. The following procedure is suggested as a way to check the fast and slow response of a sound-level meter.

a. On the instrument under test, set the LEVEL RANGE control to a range with an upper limit between 80 dB and 120 dB; use of a higher range is recommended to avoid interference from background noise. The instrument may be set to FAST response and FLAT, C or A weighting.

- b. Set the 1986 as follows:
- FREQUENCY any setting (1 kHz is generated independent of this setting)
- LEVEL level that corresponds to 6 dB below the full-scale range selected in step a.
- VARIABLE SPL **set fast/slow.**
- c. Set the SPL ADJUST control on the 1986 for a reference indication of 4 dB below full scale on the instrument under test. This will be either 116 dB, 106 dB, 96 dB, 86 dB or 76 dB, depending on the full-scale range selected.
- d. Set the 1986 VARIABLE SPL control to **fast** to produce 200-ms-duration tone bursts. Note the maximum reading on the instrument under test when the pulse occurs. This maximum reading must fall within the ranges of dB below full scale given in Table 2-7 for the corresponding sound-level-meter type and applicable standard.
- e. Change the 1986 VARIABLE SPL control to **slow** to produce 500-ms-duration tone bursts. Again, note the maximum rise of the reading on the instrument under test. This reading must also fall within the range of dB below full scale given in Table 2-7 for the applicable meter type and standard.

2.9.6 RMS Accuracy.

In practice, many signals to be measured are impulsive and contain much of their energy in peaks. A sound-measuring instrument must be designed to indicate the rms value of such signals, and its rms accuracy (crest-factor capacity) should be checked for this purpose.

The 1986 generates a sequence of tone bursts that simulate the impulsive signals found in practice. The IEC Consolidated Revision specifies tone bursts with a "crest factor" of 3 at a 40-Hz repetition frequency for checking rms accuracy, where the crest factor of a tone burst is defined as:

$$\sqrt{2 \times \frac{\text{Period}}{\text{Duration}}}$$

The tone bursts in the signal produced by the 1986 repeat every 25 ms (period) and have a 5.5-ms duration; this computes to a crest factor of 3.015. This signal meets the IEC specifications for checking the crest-factor capacity of a sound-measuring instrument as a means of determining its rms accuracy.

Table 2-7
MAXIMUM LEVELS FOR DYNAMIC CHARACTERISTICS

Standard	Response	DB below Full Scale per Meter Type			
		Type 0	Type 1	Type 2	Type 3
ANSI S1.4-1971	FAST	—	-4.0 to -6.0	-4.0 to -8.0	-4.0 to -8.0
	SLOW	—	-7.0 to -9.0	-7.0 to -10.0	-6.0 to -10.0
IEC Consolidated Revision	FAST	-4.5 to -5.5	-4.0 to -6.0	-4.0 to -7.0	-4.0 to -8.0
	SLOW	-7.5 to -8.5	-7.0 to -9.0	-6.0 to -10.0	-6.0 to -10.0

When the VARIABLE SPL control on the 1986 is set to **set crest fctr**, a steady reference tone is generated; when it is set to **crest factor**, a tone-burst signal with a crest factor of "times 3" is generated with the same rms level as the reference tone. The following procedure is suggested for checking the rms accuracy and crest-factor capacity of a sound-measuring instrument.

a. On the instrument under test, set the LEVEL RANGE control to a range that has an upper limit between 80 dB and 110 dB; a higher full-scale range such as 100 dB or 110 dB is recommended to avoid interference from background noise. The instrument may be set to FAST or SLOW response and FLAT or C weighting.

NOTE

When the 1986 is set for the crest-factor mode, the rms amplitude of the output level is continuously adjustable from 75 to 111 dB, and the 114-dB position of the LEVEL control is nonfunctional.

b. Set the 1986 as follows:

- FREQUENCY any setting (2 kHz is automatically generated in crest-factor mode)
- LEVEL level that corresponds to 6 dB below upper limit of range selected in step a
- VARIABLE SPL **set crest fctr**

c. Set the SPL ADJUST control on the 1986 for a reference indication 2 dB below full scale on the instrument under test (this will be either 108, 98, 88 or 78 dB).

d. Change the 1986 VARIABLE SPL control to **crest factor**; the 1986 now generates a tone-burst signal with a crest factor of 3, but with the same rms level as produced in the **set crest fctr** position. Note any change in reading from the reference level set in step c. The reading must not change by more than the tolerance limits given in Table 2-8.

Table 2-8		
TOLERANCE LIMITS FOR RMS-ACCURACY*		
dB Tolerance about Reference per Meter Type		
Types 0,1	Type 2	Type 3
±0.5	±1.0	±1.5

*Taken from forthcoming IEC Consolidated Revision.

2.9.7 Octave-Filter Characteristics.

The 6 frequencies generated by the 1986 are octave-band center frequencies. There are 2 important characteristics of an octave-band filter set that determine the quality of the filters: pass-band uniformity and stop-band transmission loss. Uniformity implies identical transmission of each filter at its pass band. Transmission loss refers to the attenuation of a filter at its stop-band region (region outside of pass band); the attenuation must be greater than a specified minimum limit.

The 1986 can make a limited test of these 2 characteristics. It will test for uniformity from band to band at certain frequencies, and it will provide assurance that the stop-band transmission losses (skirts) of the filters are greater than minimum specifications.

Either the acoustical or electrical output of the 1986 can be used to test the octave-band filters. The 6 bands that correspond to the 1986 frequencies can be tested for level uniformity. It is also possible to test both skirts on 4 bands, and 1 skirt on other bands.

The following procedures are suggested to make a limited test of the pass-band uniformity and stop-band transmission loss of an octave-band filter set.

a. If the electrical output of the 1986 is used, apply it to the filter set of the instrument under test. If the acoustical output of the 1986 is used, set the LEVEL RANGE control on the instrument under test to a range that has its upper limit between 80 dB and 120 dB (a higher range is preferable, to keep above ambient levels). The instrument should be set to SLOW or FAST response and the 1-kHz octave filter frequency.

b. Set the 1986 as follows:

FREQUENCY 1 kHz

LEVEL level that corresponds to 6 dB below upper limit
of range selected in step a

VARIABLE SPL CALIBRATED SPL

c. First, note the reading on the instrument under test for its 1-kHz band. Then, select the other 5 FREQUENCY positions on the 1986, one at a time, while at the same time selecting the 5 corresponding octave filter bands on the instrument under test. This allows uniformity from band to band to be checked on the filters under test.

d. The "rolloff" of filter skirts (transmission loss) below the noted reference must be equal to or greater than the minimum value listed in Table 2-9. Verify this by setting the 1986 FREQUENCY control to the frequency listed in the top horizontal row of the table, and the OCTAVE FILTER FREQ control on the instrument under test to the frequency listed in the left vertical column of the table.

2.9.8 Overshoot.

The IEC Consolidated Revision Standard specifies how a sound-measuring instrument must respond to a suddenly applied signal that is thereafter held constant. The difference between the maximum reading and the final steady-state reading is referred to as the overshoot and should not be exceeded beyond the specified tolerance. The amplitude of the suddenly applied signal is specified by the standard to be, preferably, 20 dB and its upper limit is usually specified at 4 dB below full scale on the instrument under test.

The following procedure is suggested as a way to check overshoot with the 1986:

a. On the instrument under test, set the LEVEL RANGE control to any range that has its upper limit between 80 dB and 120 dB. The instrument should be set to FAST response (or SLOW if FAST is not available) and C or A weighting.

		MINIMUM STOP-BAND TRANSMISSION LOSSES											
		Minimum Loss versus 1986 FREQUENCY Setting (dB below noted reference)											
OCTAVE FILTER FREQ Setting on Instrument Under Test (Hz)		125 Hz		250 Hz		500 Hz		1,000 Hz		2,000 Hz		4,000 Hz	
		31.5		40.0	38.7								
63		18.0	14.9	40.0	38.7								
125		Note Reference		18.0	14.9	40.0	38.7						
250		18.0	14.9	Note Reference		18.0	14.9	40.0	38.7				
500		40.0	38.7	18.0	14.9	Note Reference		18.0	14.9	40.0	38.7		
1 k				40.0	38.7	18.0	14.9	Note Reference		18.0	14.9	40.0	38.7
2 k						18.0	14.9	Note Reference		Note Reference		18.0	14.9
4 k						40.0	38.7	18.0	14.9	18.0	14.9	Note Reference	Note Reference
8 k								40.0	38.7	40.0	38.7	18.0	14.9
16 k												40.0	38.7
		IEC	ANSI	IEC	ANSI	IEC	ANSI	IEC	ANSI	IEC	ANSI	IEC	ANSI
Standard*													

*Standards referred to are IEC 225-1966 and ANSI S1.11-1966; the ANSI Standard specifies transmission losses for a Class II filter.

- b. Set the 1986 as follows:
 - FREQUENCY any setting (1 kHz is automatically generated in **set fast/slow, fast** and **slow** modes)
 - LEVEL level that corresponds to 6 dB below upper limit of range selected in step a
 - VARIABLE SPL **set fast/slow**

c. Set the SPL ADJUST control on the 1986 for a reference indication of 4 dB below full scale on the instrument under test.

d. Change the 1986 VARIABLE SPL control to **fast** or **slow** (depending on which of these was selected in step a on the instrument under test). After the indicator (meter or digital display) has decayed to near the resting point, quickly set the VARIABLE SPL control back to the **set fast/slow** position. Note the overshoot of the meter pointer, or max digital display, with respect to the reference indication established in step c. This overshoot should not be more than the level indicated in Table 2-10 for the type of sound-level meter being used.

Table 2-10
MAXIMUM TOLERANCES FOR OVERSHOOT*

Detector Response	Maximum Overshoot (in dB)† per Meter Type	
	Type 0	Types 1,2,3
FAST	0.5	1.1
SLOW	1.0	1.6

* From IEC Consolidated Revision Standard.

† Maximum allowable reading above reference level when VARIABLE SPL control is changed from **fast** or **slow** to **set fast/slow**.

2.9.9 Decay Time.

The rate at which the reading on an indicator decays when a signal is turned off is defined as the decay time. The ANSI S1.4-1971 Standard for sound-level meters states that the decay time for either a FAST-response detector or a SLOW-response detector will be essentially the same as that detector's rise time. The IEC Consolidated Revision Standard is more specific in stating that the indicator shall decay by 10 dB in a time of 0.5 s or less for FAST response, and in a time of 3.0 s or less for SLOW response. For sound-measuring instruments containing an IMPULSE detector, separate response times are specified that are described below.

The decay time of an instrument can be tested by suddenly removing a steady-state signal. The following procedure is suggested for checking the FAST, SLOW and IMPULSE decay times of an instrument with the 1986.

FAST and SLOW Responses.

- a. On the instrument under test, set the LEVEL RANGE control to the range that has 120 dB as its upper limit. The instrument should be set to FAST response (or SLOW if FAST is unavailable) and C or A weighting.

- b. Set the 1986 as follows:

FREQUENCY any setting (1 kHz is automatically generated in **set fast/slow, fast** and **slow** modes).

LEVEL 114 dB

VARIABLE SPL **set fast/slow**

- c. Set the SPL ADJUST control on the 1986 for a full-scale indication (120 dB) on the instrument under test.

- d. Turn the 1986 LEVEL control to POWER OFF. When the signal is suddenly turned off, the meter indicator should decay by 10 dB in a time of 0.5 s or less for FAST detector response, and 3.0 s or less for SLOW detector response.

IMPULSE Response. An impulse detector has a rise time that is faster than a fast detector, and a decay time slower than a slow detector. Sound-level meters that incorporate an impulse detector can be tested by the 1986 for conformity to specifications of the IEC 179 Standard. The 1986 output signal containing 200-ms tone bursts, obtained from the **fast** position of the VARIABLE SPL control, must be used for this test. Since the time constant for an impulse detector is approximately 35 ms, the detector should charge to its maximum value during the on-time of the 200-ms tone burst from the 1986; during the 1.8-s off-time of the pulse burst, the indicator's decay time must be within the tolerances specified by the standard.

The following procedure is suggested for checking the decay time of an impulse detector.

- a. On the instrument under test, set the LEVEL RANGE control to a range having an upper limit between 80 dB and 120 dB. The instrument should be set to IMPULSE response and C or A weighting.

- b. Set the 1986 as follows:

FREQUENCY any setting (1 kHz is automatically generated in the **set fast/slow** and **fast** modes)

LEVEL level that corresponds to 6 dB below the upper limit of the range selected in step a

VARIABLE SPL **set fast/slow**

- c. Set the SPL ADJUST control on the 1986 for a reference indication of full scale on the instrument under test.

- d. Change the 1986 VARIABLE SPL control to **fast**. Note how far below full scale the indicator falls between pulses. The fall from maximum value should nominally be -5.22 dB, or within a permitted tolerance range of -4.32 to -6.12 dB below full scale.

2.10 ALTITUDE AND PRESSURE CORRECTIONS.

The acoustical output of the 1986 is indicated by the LEVEL control on the panel for a normal atmospheric pressure of 760 mm (30 in.) of Hg. A correction must be made to this output if the instrument is used at a pressure appreciably different from the normal pressure. Correction curves are given in Figure 2-5 to show the change in sound-pressure level with a change in altitude and atmospheric pressure. There is a curve for each 1986 frequency that is to be used when determining the sound-pressure level of the output at a specific altitude or barometric pressure (most barometers are

calibrated to read pressures corrected to sea level). Note that 125, 250 and 500 Hz are included on the same curve in Figure 2.5.

An example of how to use Figure 2-5 follows:

Conditions of Measurement:

FREQUENCY	1000 Hz
ALTITUDE	2.4 km (8000 ft)
Correction from Figure 2-5	-1.8 dB
1986 LEVEL setting	84 dB
Actual 1986 output	82.2 dB (84-1.8 dB)

For this example, the acoustical output of the 1986 is 1.8 dB less than the indication of the LEVEL control. That is, for a LEVEL-switch setting of 84 dB, the actual output is 82.2 dB; therefore, the sensitivity of the instrument under test would be adjusted for a reading of 82.2 dB in this example.

2.11 PRESSURE-TO-FREE-FIELD CORRECTIONS.

The cavity within the 1986 transducer assembly creates a microphone frequency-response condition referred to as "pressure response." Pressure response is characterized by a sound field that produces a uniform sound pressure over the diaphragm surface of a microphone. This condition is realized by the 1986 when the microphone being calibrated is tightly coupled within its specially shaped cavity of small volume.

The 1986 can be used to calibrate a sound-measuring instrument that uses either a "pressure-response" or "free-field-response" microphone; the latter is designed to produce a flat-frequency response to sounds within a free field rather than a pressure field. (A particular free-field microphone may be designated for either "random" or "perpendicular" sound incidence with respect to the plane of the microphone's diaphragm.) Since free-field incidence is not simulated within the small-dimensioned cavity of the 1986, where its transducer is tightly coupled to a microphone, correction factors are sometimes necessary to account for the difference between free-field and pressure incidence.

The amount of correction factor that is required depends on the frequency of the calibration signal and the type of microphone being calibrated. There is no appreciable correction factor necessary at frequencies below 1 kHz but, for frequencies of 1 kHz and higher, corrections are generally necessary.

Table 2-11 gives the pressure-to-free-field corrections that are necessary at higher frequencies for various microphones. These correction factors are computed from the difference between the perpendicular or random response that a microphone is designed for, and the actual pressure response within the cavity of the 1986. Thus, a correction will always result in adjusting the sensitivity of the instrument under test for a reading *lower* than the level indicated on the 1986 panel by the LEVEL switch. (The correction is *added* to the SPL indication of the instrument under test *before* comparing that indication with the calibrated SPL output of the 1986, as indicated on its panel by the LEVEL switch.) Sound-Level meters that comply with the ANSI S1.4-1971 Standard use a microphone idealized for a random-incidence response, whereas meters that comply with the IEC Standards use a microphone idealized for a perpendicular-incidence response.

Table 2-11
PRESSURE-TO-FREE-FIELD CORRECTIONS*†

Microphone Mfr. & Type	GR Adaptor Used	1-kHz Correction (dB)	2-kHz Correction (dB)	4-kHz Correction (dB)
Flat-Response-to-Random-Incidence Microphones:				
GR 1961-9610 or -9601 (1-in. electret)	none	0.0	0.1	1.2
GR 1962-9610 or -9601 (1/2-in. electret)	1987-7061	-0.0	0.0	0.2
GR 1971 (1-in. ceramic)	none	0.0	0.1	1.4
GR 1983 Sound-Level Meter (1/2-in. ceramic)	1987-7061	0.0	0.1	0.3
GR 1954 Noise Dosimeter (3/8-in. ceramic)	1987-7076 & 1987-7095	0.0	0.0	0.2
Flat-Response-to-Perpendicular- Incidence Microphones:				
GR 1961-9611 or -9602 (1-in. electret)	none	0.3	1.0	3.5
GR 1962-9611 or -9602 (1/2-in. electret)	1987-7061	0.1	0.3	1.0
B & K 4131/45 (1-in. cond) (GRID ON)	O-ring (5855-6920)	0.3	1.0	2.9
B & K 4133/65 (1/2-in. condenser)	1987-2050	0.0	0.3	0.8
B & K 4135 (1/4-in. condenser)	1987-2060	0.0	0.0	0.2

* Measurement Conditions: Atmospheric Pressure, 760 mm (30 in.) of Hg.
 Temperature, +20°C (68°F).

† To be *added* to sound-pressure-level (SPL) indication of instrument under test; this corrected indication is *then* compared with calibrated SPL output of 1986 (indicated on panel by LEVEL switch).

NOTE

Corrections listed in Table A of Condensed Operating Instructions incorporate combined effect of pressure-to-free-field correction (Table 2-11) and microphone-volume/high-frequency correction (Table 2-12).

2.12 MICROPHONE-VOLUME AND HIGH-FREQUENCY CORRECTIONS.

2.12.1 Combined Microphone-Volume/High-Frequency Corrections.

The sound-pressure-level (SPL) developed in the 1986 transducer cavity is dependent upon several factors, including volume of air, diaphragm stiffness (both

microphone and driving transducer) and wavelength factors. Thus, the SPL reading on an instrument under test may require a correction to compensate for these factors, depending on the particular microphone being utilized.

The 1986 transducer cavity is designed to produce the calibrated SPL output (indicated on panel by position of LEVEL switch) upon the diaphragm of the 1-in. GR 1961 Electret-Condenser Microphone. This microphone has an “effective volume” of 0.5 cm³. The “effective volume” of a microphone is made up of front volume and equivalent volume. Front volume is the volume of air between the diaphragm and the front surface of the grid; equivalent volume represents the volume of air enclosed in a rigid cavity having the same acoustic impedance as the front surface of the microphone diaphragm.

At higher frequencies (2 kHz and, especially, 4 kHz) the wavelength of the sound produced in the cavity becomes of the same order of magnitude as cavity and microphone dimensions. The sound field inside the cavity becomes less uniform and the slight differences in the microphone front end design can produce a change in the distribution of sound pressure across the diaphragm.

These 2 considerations — microphone-volume variations and wavelength effects — are both significant only at the 2 highest frequencies (2 kHz and 4 kHz) of the 1986 (one exception to this is discussed in the following para 2.12.2). This allows a combined correction factor that accounts for both of these effects; Table 2-12 lists these combined correction factors for various microphones. If a microphone being calibrated by the 1986 requires a correction, it should be *added* to the SPL indication on the instrument under test *before* that indication is compared with the calibrated output of the 1986 (shown on panel by the position of the LEVEL switch).

NOTE

For an application that requires 2 corrections, one from Table 2-11 and one from Table 2-12, it may be preferable to use Table A in the Condensed Operating Instructions, which contains combined corrections from these 2 tables.

2.12.2 Microphone-Volume Corrections at Low Frequencies.

The microphone-volume corrections cited in para 2.12.1 are significant only at the high frequencies of the 1986 (2 kHz and 4 kHz). Thus, they could be combined in Table 2-12 with the wavelength-effect corrections, which are also manifested only at these high frequencies.

One microphone, the 1-in. B & K 4131 or 4132 Microphone, also requires a microphone-volume correction at the low frequencies of the 1986. These low-frequency microphone-volume corrections are listed in Table 2-13. This correction should be *added* to the SPL indication of the instrument under test *before* that instrument’s indication is compared with the calibrated SPL output of the 1986 (indicated on its panel by the LEVEL switch).

NOTE

Table 2-13 lists only the lower-frequency corrections for the B & K 4131/32 Microphone. Refer to Table 2-12 for 2-kHz and 4-kHz corrections for this microphone.

Table 2-12

COMBINED MICROPHONE-VOLUME/HIGH-FREQUENCY CORRECTIONS*

Microphone Mfr. and Type	GR Adaptor Used	2-kHz Correction (dB)	4-kHz Correction (dB)
Random-Incidence-Response Microphones:			
GR 1961-9610 or -9601 (1-in. electret)	None	0.0	0.0
GR 1962-9610 or -9601 (1/2-in. electret)	1987-7061	0.1	0.8
GR 1971 (1-in. ceramic)	None	0.0	-0.2
GR 1983 Sound Level Meter (1/2-in. ceramic)	1987-7061	0.1	0.8
GR 1954 Noise Dosimeter (3/8-in. ceramic)	1987-7076 and 1987-7095	0.1	0.3

Perpendicular-Incidence-Response Microphones:			
GR 1961-9611 or -9602 (1-in. electret)	None	0.0	0.0
GR 1962-9611 or -9602 (1/2-in. electret)	1987-7061	0.1	0.8
† B & K 4131/45 (1-in. cond) (GRID ON)	5855-6920 (O-ring)	0.2	0.6
B & K 4133/65 (1/2-in. condenser)	1987-2050	0.0	0.2
B & K 4135 (1/4-in. condenser)	1987-2060	0.0	-0.4

Pressure-Response Microphones (GRID ON):			
Western Electric 640AA, 4160 (1-in. condenser)	None	-0.2	-0.5
Tokyo Riko MR103 (1-in. condenser)	None	-0.2	-0.5
B & K 4132 (1-in. condenser) †	5855-6920 (O-ring)	0.2	0.6
B & K 4134 (1/2-in. condenser)	1987-2050	0.0	0.2
B & K 4136 (1/4-in. condenser)	1987-2060	0.0	-0.4

† Refer to Table 2-13 for microphone-volume corrections at lower frequencies.

* To be added to the sound pressure level (SPL) indication of instrument under test; that corrected indication is then compared with SPL output of the 1986 (indicated on panel by LEVEL switch).

2.13 AC OUTPUT.

An electrical version of the calibrated signal produced by the 1986 is available at the AC OUTPUT connector, which is recessed in the left side panel behind a snap button (see Figure 2-1). This connector is a miniature (0.097-in. diameter) phone jack, Switchcraft Type TR-2A (GR P/N 4260-1110); it mates with a Switchcraft Type 850

Table 2-13
MICROPHONE-VOLUME CORRECTIONS AT LOW FREQUENCIES*

Microphone Mfr. & Type	GR Adaptor Used	125-Hz Correction (dB)	250-Hz Correction (dB)	500-Hz Correction (dB)	1-kHz Correction (dB)
B & K 4131/32, 4144/45	5855-6920 (O-ring)	0.6	0.6	0.5	0.4

*To be *added* to sound-pressure-level (SPL) indication of instrument under test; that corrected indication is *then* compared with calibrated SPL output of 1986 (indicated on panel by LEVEL switch).

miniature phone plug (GR P/N 4270-1110). The snap button can be popped off by inserting a fingernail behind it; the button is attached to the panel by a plastic strap to prevent it from being lost. The voltage of this ac output is proportional to the sound-pressure level; a 230-mV-rms nominal output corresponds to a 114-dB SPL.

The output from this connector is provided by a nominal 600-Ω shortable source. The frequency response of an instrument being calibrated with the ac output is actually flatter than its response to the acoustical output, since it is not influenced by pressure variations or by cavity and microphone-volume considerations.

Typically, an application for its use would be the calibration or check of a sound-level meter electrically, i.e., excluding the microphone. One example where testing of this type might be done would be in an area of high ambient levels.

2.14 USE WITH GR 1954 NOISE DOSIMETER.

The calibration of the monitor on the GR 1954 Noise Dosimeter can be checked using the 1986 in place of the 1954 Indicator's calibrator. The GR 1987-7076 Adaptor and GR 1987-7095 Adaptor Cap are required; these are included in the GR 1987-9600 Microphone Adaptor Set (see Figure 1-3).

The calibration procedure follows:

- a. Insert the 1954 monitor into the 1954 Indicator as normally done for a routine calibration check (refer to the 1954 instruction manual).
- b. Set the dB RANGE switch on the 1954 monitor to 80-130 dB, and the ON/HOLD switch to QN.
- c. Insert the 1954 microphone into the 1986 transducer cavity using the 1987-7076 adaptor and 1987-7095 adaptor cap (refer to para 2.7.3 for instructions on installing these adaptors).
- d. Set the 1986 as follows:
 - FREQUENCY 1 kHz
 - LEVEL 114 dB
 - VARIABLE SPL CALIBRATED SPL
- e. Reset the monitor by depressing DISPLAY and RESET simultaneously on the 1954 Indicator.

f. Depress the CALIBRATE button on the 1954, and hold it for 10 s until the display reaches a steady value. Adjust the CAL control on the monitor for a reading on the indicator of 0.087. This number applies to the 1954-9710 monitor, which has a 5-dB exchange rate. The calibration number for the 1954-9730 monitor is 0.78.

A cross-check of the above calibration can be made by comparing the results using the 1986 calibrator with the results using the 1954 Indicator's calibrator. Some discrepancy is likely, and the tolerances of the 1986 output level and the 1954 Indicator output level must be taken into account when making this comparison.

Standards—Section 3

3.1 GENERAL.

The interpretation and knowledge of specifications stated in applicable standards is an important consideration when verifying the characteristics of a sound-measuring instrument. For that reason, excerpts from the pertinent standards are reprinted in this section for reference purposes. No attempt is made to reproduce the standards in their entirety, but only to provide information relevant to testing with the 1986. This may be especially helpful for the 1986 user who does not have access to fully published copies of the standards.

The excerpts contained in this section are from the ANSI Standard S1.4-1971 and the forthcoming IEC Consolidated Revision only (see footnotes, para 2.9.1). The topics taken from these standards are those emphasizing the tests, described in Section 2, that the 1986 is capable of performing. The purpose of these tests is to ensure that the instrument under test conforms to specifications established by the standards before it is used to make measurements.

3.2 SENSITIVITY.

3.2.1 General.

The excerpt reprinted below can be used for reference when performing the sensitivity test, described in para 2.9.2.

3.2.2 ANSI Excerpt.

The following excerpt is taken from para 6.2, 6.2.1, 6.2.2, 6.2.3, 6.2.4, 6.2.5, and 6.2.6 of the ANSI Standard S1.4-1971; it provides specifications for checking the sensitivity of an instrument.

6.1 Sensitivity Checks.

6.2.1 A Type 1 Instrument shall include a means to check and maintain sensitivity without resort to additional equipment. For this purpose, the instrument shall contain either an acoustic coupler to check the sensitivity of the entire sound level meter or means to check the electrical sensitivity of only the amplifier and indicating instrument. If the latter approach is used, it must be possible to check the sensitivity of the entire sound level meter with an acoustic calibrator of the coupler type.

6.2.2 It is recommended that the Type 2 instrument be in accordance with 6.2.1. However, if the instrument does not contain means for checking its sensitivity, it shall be designed so that it is possible to check the sensitivity of the entire sound level meter with an acoustic calibrator of the coupler type.

6.2.3 A Type 3 instrument shall be designed so that it is possible to check the sensitivity of the entire sound level meter with an acoustic calibrator of the coupler

type, or so that it is possible to check its electrical sensitivity by the insert voltage method. (See 2.1 of American National Standard S1.10-1966).

6.2.4 For a Type 1 or 2 instrument, the internal or external electrical sensitivity check signal shall be sinusoidal, having a frequency within the range of 200 to 1250 Hz, and be stated by the manufacturer. For a Type 3 instrument, any frequency stated by the manufacturer may be used. The sound level meter shall be in either the C weighting or "flat" operation during calibration. However, if the instrument is a Type S and has no C or "flat" weighting network, it shall be calibrated at a frequency in the range of 200 to 1250 Hz, selected such that the relative response level gradient is less than 1.5 decibels per one-third octave.

6.2.5 For a Type 1 or 2 instrument, the acoustic sensitivity check signal shall be a pure tone having a frequency within the range 200 to 1250 Hz, and be stated by the manufacturer. The sound level meter shall be in either the C weighting or "flat" operation during calibration. However, if the instrument is a Type S and has no C or "flat" weighting network, it shall be calibrated at a frequency in the range of 200 to 1250 Hz, selected such that the relative response level gradient is less than 1.5 decibels per one-third octave.

6.2.6 For a Type 3 instrument, the acoustical or electrical sensitivity check signal and method for checking shall be specified by the manufacturer.

3.3 FREQUENCY-WEIGHTING CHARACTERISTICS.

3.3.1 General.

The excerpt reprinted below can be used for reference when performing the frequency-weighting test, described in para 2.9.3. When Table 3-1 is used, refer to Figure 2-4 for a graphical presentation of the nominal frequencies and levels listed.

3.3.2 Combined ANSI and IEC Excerpt.

The following tables (Tables 3-1, 3-2, 3-3, 3-4 and 3-5) are taken from Tables 1, 2, 3, and 4 of the ANSI Standard S1.4-1971 and from Tables IV and V of the IEC Consolidated Revision; they can be used to check the frequency-weighting characteristics of an instrument. The tolerances listed in these tables apply to the complete instrument, comprising the microphone, amplifier, weighting network and detector-indicator.

NOTE

Only those frequencies available on the 1986 are listed in the tables.

3.4 LINEARITY AND TRACKING.

3.4.1 General.

The excerpts reprinted below can be used for reference when checking the indicator linearity and LEVEL-RANGE-control accuracy of an instrument, as described in para 2.9.4. The indicator-linearity test checks for the tracking accuracy of the detector-indicator across its total span; para 3.4.2 and 3.4.3 contain excerpts pertinent to this test. The LEVEL-RANGE-control test checks for the tracking accuracy of the instrument as it is changed from one range to another; para 3.4.4 and 3.4.5 contain

Table 3-1

NOMINAL FREQUENCY-WEIGHTING LEVELS*†

Nominal Frequency (Hz)	Exact Frequency (Hz)	A-Weighting Nominal Level‡ (dB)	B-Weighting Nominal Level‡ (dB)	C-Weighting Nominal Level‡ (dB)
125	125.9	-16.1	-4.2	-0.2
250	251.2	-8.6	-1.3	0
500	501.2	-3.2	-0.3	0
1,000	1,000	0	0	0
2,000	1,995	+1.2	-0.1	-0.2
4,000	3,981	+1.0	-0.7	-0.8

*Taken from Table 1 in ANSI S1.4-1971 and Table IV in IEC Consolidated Revision.

†All dB values listed with respect to reference level of 0 dB, and for free-field or random-incidence frequency response in reference direction.

‡Refer to frequency-weighting curves in Figure 2-4.

Table 3-2

TOLERANCES FOR LEVELS IN TABLE 3-1*†

Nominal Frequency (Hz)	Tolerances (in dB) per Meter Type			
	Type 0‡	Type 1	Type 2	Type 3
125	±0.7	±1.0	±1.5	±2.0
250	±0.7	±1.0	±1.5	±2.0
500	±0.7	±1.0	±1.5	±2.0
1,000	±0.7	±1.0	±1.5	±2.0
2,000	±0.7	±1.0	±2.0	±3.0
4,000	±0.7	±1.0	±3.0	±5.0

*Taken from Table V in IEC Consolidated Revision.

†Tolerances are same for all weighting characteristics; substitute tolerance of zero for chosen reference frequency (normally 1 kHz).

‡Manufacturer provides frequency-response curves for Type 0 Meter.

Table 3-3

FREQUENCY-WEIGHTING TOLERANCES FOR TYPE 1 METERS*†

Frequency (Hz)	A-Weighting (dB)	B-Weighting (dB)	C-Weighting (dB)
125	±1	±1	±1
250	±1	±1	±1
500	±1	±1	±1
1,000	±1	±1	±1
2,000	±1	±1	±1
4,000	±1	±1	±1

*Taken from Table 2 in ANSI S1.4-1971.

†For sound at random incidence.

Table 3-4

FREQUENCY-WEIGHTING TOLERANCES FOR TYPE 2 METERS*†

Frequency (Hz)	A-Weighting (dB)	B-Weighting (dB)	C-Weighting (dB)
125	±2.5	±2.0	±1.0
250	±2.5	±1.5	±1.0
500	±2.0	±1.5	±1.0
1,000	±2.0	±2.0	±1.5
2,000	±3.0	±3.0	±2.5
4,000	+5.5, -4.5	+5.5, -4.5	+5.0, -4.0

*Taken from Table 3 in ANSI S1.4-1971.

†For sound at random incidence.

Table 3-5

FREQUENCY-WEIGHTING TOLERANCES FOR TYPE 3 METERS*†

Frequency (Hz)	A-Weighting (dB)	B-Weighting (dB)	C-Weighting (dB)
125	±3.0	±2.5	±2.0
250	±3.0	±2.5	±2.0
500	±3.0	±2.5	±2.0
1,000	±2.0	±2.0	±1.5
2,000	±3.0	±3.0	±2.5
4,000	±5.5	±5.5	±5.0

*Taken from Table 4 in ANSI S1.4-1971.

†For sound at random incidence.

excerpts pertinent to this test. Para 3.4.6 contains an excerpt that specifies a means to check the combined linearity of the indicator and LEVEL RANGE control.

3.4.2 ANSI Excerpt for Indicator Linearity.

The following excerpt is from para 5.1, 5.1.1, 5.1.2 and 5.1.3 of the ANSI Standard S1.4-1971; it provides specifications for checking the linearity of the instrument's detector-indicator.

5.1 Scale of the Indicating Instrument.

5.1.1 The scale of the indicating instrument shall be graduated in decibels in steps of 1 decibel, over a range of at least 15 decibels.

5.1.2 It is recommended that the scale be graduated from +10 decibels to the lower limit.

5.1.3 The scale of the indicating instrument shall be accurate with ±(0.2 decibel + 2 percent of the number of decibels down from full-scale indication) for a Type 1 instrument, ±(0.2 decibel + 3 percent of the number of decibels down from full-scale indication) for Type 2 instruments, and ±(0.4 decibel + 6 percent of the number of decibels down from full-scale indication) for Type 3 instruments.

3.4.3 IEC Excerpt for Indicator Linearity.

The following excerpt is from para 7.10 and Table XIII of the IEC Consolidated Revision; it provides specifications for checking the linearity of an instrument's detector-indicator.

7.10 The instrument shall satisfy a test for differential level linearity in addition to the test given in Sub-clause 7.9. Differential level linearity error is measured between any two arbitrarily chosen points which are up to 10 dB apart, in the range of the indicator. The maximum error, both inside and outside the primary indicator range, permitted for each type of sound level meter for points separated by 1 dB and for points separated by up to 10 dB is given in Table 3-6.

NOTE

Primary indicator range of a sound-level meter is defined as a specified range of the indicator for which the sound-level-meter readings are within particularly close tolerances on level linearity. The specific primary range for a particular instrument is specified by the manufacturer, and usually refers to the top 15 to 20 dB of the indicator's range.

Table 3-6

**TOLERANCE ON DIFFERENTIAL LEVEL LINEARITY IN THE
FREQUENCY RANGE 31.5 Hz TO 8,000 Hz
(20 – 12,500 Hz FOR TYPE 0) IN DECIBELS***

Instrument Type	Meter Type			
	0	1	2	3
<i>Readings inside primary indicator range for points separated by up to 10 dB</i>	±0.4	±0.4	±0.6	±1
<i>Readings outside primary indicator range for points separated by up to 10 dB</i>	±0.6	±1	±1.5	±2

* Taken from Table XIII in the IEC Consolidated Revision.

3.4.4 ANSI Excerpt for LEVEL-RANGE-Control Accuracy.

The following excerpt is from para 3.2.2 of the ANSI Standard S1.4-1971; it provides specifications for checking the accuracy of an instrument's LEVEL RANGE control and attenuator.

3.2.2 All settings of the sensitivity range attenuator, if provided, shall be accurate for pure tones within the following tolerance limits with respect to the setting for 80 decibels. (If no 80 decibel setting is provided, the tolerance limits shall apply with respect to a reference setting stated by the manufacturer.)

Type 1
within ±0.5 dB 22.4 to 11200 Hz

	<i>Type 2</i>
<i>within ±0.5 dB</i>	<i>63 to 2000 Hz</i>
<i>within ±1.0 dB</i>	<i>22.4 to 11200 Hz</i>
	<i>Type 3</i>
<i>within ±1.0 dB</i>	<i>63 to 4000 Hz</i>
<i>within ±2.0 dB</i>	<i>31.5 to 8000 Hz</i>

If more than one sensitivity range is provided, it is recommended that the attenuator steps be at 10 decibel intervals.

3.4.5 IEC Excerpt for LEVEL-RANGE-Control Accuracy.

The following excerpt is from para 6.3 and Table VI of the IEC Consolidated Revision; it provides specifications for checking the accuracy of the instrument's LEVEL RANGE control and attenuator.

6.3 When a level range control is included, it shall introduce errors less than those given in Table 3-7 for all settings with reference to a range setting specified by the manufacturer as the reference range.

<i>Table 3-7</i>				
<i>TOLERANCES ON LEVEL RANGE CONTROL ACCURACY IN VARIOUS FREQUENCY RANGES IN DECIBELS*</i>				
<i>Frequency (Hz)</i>	<i>Meter Type</i>			
	<i>0</i>	<i>1</i>	<i>2</i>	<i>3</i>
<i>31.5 – 8,000</i>	<i>±0.3</i>	<i>±0.5</i>	<i>±0.7</i>	<i>±1</i>
<i>20 – 12,500</i>	<i>±0.5</i>	<i>±1</i>	<i>—</i>	<i>—</i>

*Taken from Table VI in the IEC Consolidated Revision.

3.4.6 IEC Excerpt for Combined Linearity of Indicator and LEVEL RANGE Control.

The following excerpt is from para 7.9 and Table XII of the IEC Consolidated Revision; it provides specifications for checking the combined linearity of an instrument's detector-indicator, LEVEL RANGE control and attenuator.

7.9 The linearity of the system consisting of the detector-indicator and any manual or automatic range controls shall be tested and shall satisfy the requirements of Table 3-8. The reference level for testing linearity is the reference sound pressure level. Note: In the previous standards for sound level meters based only on analogue indicating instruments, the level linearity tolerance was given by the sum of the tolerance of the level range control and the meter scale graduation. Since this standard permits various other indicating systems, level linearity must be specified in a different manner intended to produce equivalent results.

Table 3-8

**TOLERANCES ON LEVEL LINEARITY REFERRED TO THE
REFERENCE SOUND PRESSURE LEVEL*
IN THE FREQUENCY RANGE 31.5 – 8,000 Hz
(20 – 12,500 Hz FOR TYPE 0) IN DECIBELS†**

Instrument Type	Meter Type			
	0	1	2	3
Reading in primary ‡ indicator range	±0.4	±0.7	±1	±1.5
Readings outside primary ‡ indicator range	±0.6	±1	±1.5	±2

* Reference sound-pressure level is defined as the level specified by the manufacturer to calibrate the absolute sensitivity of a sound-measuring instrument.

† Taken from Table XII in the IEC Consolidated Revision.

‡ See note in para 3.4.3.

3.5 DYNAMIC CHARACTERISTICS.

3.5.1 General.

The excerpts reprinted below can be used for reference when performing the dynamic-characteristics test, described in para 2.9.5.

3.5.2 ANSI Excerpt.

The following excerpt is taken from para 5.3, 5.3.1, 5.3.2, 5.3.3, 5.3.4, and 5.3.5 of the ANSI Standard S1.4-1971; it provides specifications for checking the FAST and SLOW dynamic characteristics of an instrument.

5.3 Fast Dynamic Characteristic. The sound level meter shall possess the following dynamic characteristics which may be identified as "FAST":

5.3.1 If a pulse of sinusoidal signal having a frequency of 1000 Hz and duration of 0.2 second is applied, the maximum reading for a Type 1 instrument shall be 0 to 2 decibels less than the reading for a steady signal of the same frequency and amplitude. For Type 2 and Type 3 instruments, the maximum reading shall be 0 to 4 decibels less.

5.3.2 If a sinusoidal signal at any frequency between 125 and 8000 Hz is suddenly applied and thereafter held constant, the maximum reading shall exceed the final steady reading by 0 to 1.1 decibels.

5.3.3 The above requirements hold for a steady reading 4 decibels less than the full-scale reading.

5.3.4 It is recommended that the decay time be essentially the same as the rise time.

5.4 Slow Dynamic Characteristic. The sound level meter may also be provided with the following dynamic characteristics which may be identified as "SLOW":

5.4.1 If a pulse of sinusoidal signal having a frequency of 1000 Hz and duration of

0.5 second is applied, the maximum reading for a Type 1 instrument shall be 3 to 5 decibels less than the reading for a steady signal of the same frequency and amplitude. For Type 2 and Type 3 instruments, the maximum reading shall be 2 to 6 decibels less.

5.4.2 If a sinusoidal signal at any frequency between 63 and 8000 Hz is suddenly applied and thereafter held constant, the maximum reading shall exceed the final steady reading by 0 to 1.6 decibels.

5.4.3 The above requirements hold for a steady reading of 4 decibels less than the full-scale reading.

5.4.4 The steady reading for any sinusoidal signal of any frequency between 31.5 and 8000 Hz shall not differ from the corresponding "FAST" reading by more than 0.1 decibel for Types 1 and 2, and 0.3 decibel for Type 3.

5.4.5 It is recommended that the decay time be essentially the same as the rise time.

3.5.3 IEC Excerpt.

The following excerpt is taken from para 7.2 and 9.4.1, and from Table VIII, of the IEC Consolidated Revision; it provides specifications for checking the FAST and SLOW dynamic characteristics of an instrument.

7.2 The dynamic characteristics of the detector-indicator must be such that it will respond to tone bursts as specified in Table 3-9 and to a suddenly applied signal or step in signal level with overshoot as specified in Table 3-11. When the suddenly applied signal is turned off, the meter indicator shall decay by 10 dB in a time of 0.5 s or less for F and 3.0 s or less for S.

9.4.1 The rise times of the F and S detector-indicators shall be tested using single sinusoidal bursts at a frequency in the range from 1000 to 2000 Hz. For a single burst with a duration T and an amplitude that produces an indication 4 dB below the upper limit of the primary indicator range (see NOTE in para 3.4.3) when the signal is continuous, the indication for the burst signal is given in Table 3-9. The requirements shall be met for all sensitivity ranges of the sound level meter. For test signals of short duration, it may be necessary to increase the level of the input signal by 10 dB to get a reading in the range of the indicator. It is also recommended that the rise time be tested for an indication of the steady level 5 dB above the lower limit of the indicator range at 200 ms for F and 500 ms for S.

3.6 RMS ACCURACY.

3.6.1 General.

The excerpts reprinted below can be used for reference when performing the rms-accuracy test, described in para 2.9.6.

3.6.2 ANSI Excerpt.

The following excerpt is taken from para 5.2 of the ANSI Standard S1.4-1971; it provides specifications for checking the rms accuracy of an instrument.

Table 3-9
TOLERANCES FOR DYNAMIC CHARACTERISTICS*

Detector Indicator Characteristics	Duration of Test Tone Burst (ms)	Maximum Response to Test Tone Burst Referred to Response to Continuous Signal (dB)	Tolerances on Maximum Response for Each Instrument Type (dB)			
			0	1	2	3
	<i>Continuous</i>	<i>0</i>				
<i>F</i>	200	-1.0	±0.5	±1	±1	±1
($\tau = 125 \text{ ms}$)	5	-14.1	±2	-	-	-
<i>S</i>						
($\tau = 1,000 \text{ ms}$)	500	-4.1	±0.5	±1	±2	±2

* Taken from Table VIII in the IEC Consolidated Revision.

5.2 Rule of Combination for Complex Sounds. The indicating instrument shall be of the square law type as verified by the Rule of Combination Measurement. The rule of combination shall be satisfied within 0.5 decibel for the Type 1 and Type 2 meters and within 1.1 decibels for the Type 3 meter.

3.6.3 IEC Excerpt.

The following excerpt is taken from para 9.4.2 and Table VII of the IEC Consolidated Revision; it provides specifications for checking the rms accuracy of an instrument.

9.4.2 The steady-state rms-accuracy of the detector-indicator system is tested by comparing the indication of a continuous sequence of rectangular pulses and for a sequence of tone bursts to that for a reference sine wave signal. It is recommended that the sine wave signal have a frequency of 2 kHz. The rectangular test pulses shall have durations of 200 μs and rise times less than 10 μs . The tone burst test signal shall consist of an integral number of sine waves (2 kHz) starting and ending at zero crossing. The repetition frequency shall be 40 Hz. The rectangular pulse test shall be performed using both positive going and negative going pulses. The test shall be performed at 2 dB below the upper limit of the primary indicator range (see NOTE in para 3.4.3) and at intervals of 10 dB below this level down to the lowest level that produces an indication of more than 3 dB. The tolerances in Table 3-10 shall be met over the entire range of weighted sound pressure levels which the instrument is designed to measure.

3.7 OVERSHOOT.

3.7.1 General.

The excerpts reprinted below can be used for reference when performing the overshoot test, described in para 2.9.8.

3.7.2 ANSI Excerpt.

Refer to para 3.5.2 (ANSI para 5.3 and 5.4), since this excerpt pertains to the overshoot test as well as the dynamic-characteristics test.

Table 3-10

TOLERANCES FOR RMS ACCURACY
(CREST FACTOR ≤ 3)*

Meter Type	Maximum Error For Detector-Indicator (dB)
0	± 0.5
1	± 0.5
2	± 1
3	± 1.5

*Taken from Table VII in the IEC Consolidated Revision.

Table 3-11

TOLERANCES FOR OVERSHOOT*

Detector-Indicator Characteristics	Maximum Overshoot in Decibels for Instrument Type			
	0	1	2	3
F	0.5	1.1	1.1	1.1
S	1.0	1.6	1.6	1.6

*Taken from Table IX in the IEC Consolidated Revision.

3.7.3 IEC Excerpt.

The following excerpt is taken from para 9.4.1 and Table IX of the IEC Consolidated Revision; it provides specifications for checking the overshoot of an instrument.

9.4.1 The overshoot for the F and S detector-indicators shall be tested using a step in amplitude that is suddenly applied and thereafter held constant. The maximum readings shall not exceed the final steady reading by more than the amounts given in Table 3-11 when the test signal has a frequency between 100 Hz and 8 kHz. When the range of the indicator is 20 dB or less, the test shall be met for a steady-state level corresponding to 4 dB below the upper limit of the primary indicator range, and it is recommended that the test also be met at other levels.

When the range of the indicator is more than 20 dB, the tests of rise time and overshoot shall be conducted using signals that step in amplitude by 20 dB. The tests shall be performed at 4 dB below the upper limit of the primary indicator range and at intervals of 10 dB below for all signals that produce an indication. When a digital indicator is used, it is recommended that the tests for rise time and overshoot be performed with the instrument set to the maximum hold mode.

Since most of the operational amplifiers in the 1986 require plus and/or minus voltage supplies, the battery is converted to a positive-and-negative supply by “splitter” U12C, which is a unity-gain buffer. The output of U12C sets the center voltage of the battery at ground reference; thus, in effect, the battery “floats” with respect to ground.

Zener diode CR3 performs 2 functions: it supplies the plus side of voltage (+3.5 V) and it is the main reference to ground. CR3 is driven by constant-current FET-source Q2 to minimize changes in the reference supply voltage versus battery voltage. The voltage rating of CR3 is 5.0 V \pm 1%; this particular diode (IN750B) was selected for its low temperature compensation. Resistors R34, R35 and R36 form a voltage-divider network that divides the 5-V output of CR3 into the +0.5-V oscillator reference voltage and the +3.5-V positive supply voltage.

4.2.2 Battery-Low Detector.

The output of the power supply is continuously monitored by the battery-low test circuit that contains U12B. This circuit will automatically shut down the oscillator (U11B) when the battery voltage drops below 7.0 V. This prevents a weak, intermittent or fluctuating calibrator output that could result from insufficient battery power.

U12B senses the state of the battery. Since the plus supply is fixed at +3.5 V, the voltage at pin 5 of U12B (U12.5) will vary with the minus supply (-3.5 to -5.5 V), which varies with the battery voltage. When the battery voltage is 7.0 V, the minus supply is -3.5 V; the voltage at the center of the 2 resistors R37 and R38 is then 0 V (neglecting approximately 0.15-to-0.2-V hysteresis effects of R59), which is the ground voltage. When U12.5 becomes more positive than ground, the output of U12B (“BATLOW”) switches to positive; this positive output, at U12.7, is gated through CR4 to the oscillator control circuit, where it disables the oscillator. The output voltage at U12.7 is typically one of these two voltages: plus supply voltage (+3.5 V) less 0.6 V, or minus supply voltage (-3.5 to -5.0 V) plus 1.4 V.

4.2.3 Wein-Bridge Oscillator.

The oscillator is a multifrequency Wein-bridge circuit; its individual frequency elements are switched by frequency-control switches U17, 18 and 19. Its output level is regulated by a level-control circuit comprised of a detector (U11D) and the automatic gain control (AGC) of the oscillator (U11B). The 3 main elements of the oscillator — the bridge circuit, detector and AGC mechanism — are discussed separately below.

Bridge Circuit. In this Wein-bridge circuit, C1 and C2 are fixed capacitors and the resistive elements are selected by CMOS gate switches. R11 and R12 are the resistors for the lowest frequency (125 Hz); they are always in place. Resistors R1-R10, which shunt R11 and R12, are selected for the 5 other frequencies of the 1986. The switch resistance of the CMOS elements is taken into account in the frequency-select resistors. The highest frequency (4 kHz) requires 2 CMOS elements in shunt to minimize device-to-device variation and temperature effects. Note that the actual output frequency of the 1986 (the center frequency of the oscillator) is not exactly the same as the nominal output frequency; Table 4-1 gives these values.

Table 4-1

OSCILLATOR CENTER FREQUENCIES

Nominal Output Frequency (Hz)	Actual Oscillator Center Frequency (Hz)
125	125.9
250	251.2
500	501.2
1,000	1,000
2,000	1,995
4,000	3,981

The oscillator (U11B) utilizes a wide-bandwidth FET-input op amp for its low input loading and low phase shift. The phase shift from the oscillator output (U11.7) to the Wein-bridge output (U11.5) is nominally 0° at the center frequency, with an attenuation of "times 1/3." In order to sustain oscillation, it is necessary to control the gain of U11B at "times 3"; this is done via the detector and AGC network.

Detector. The purpose of the detector is to provide a dc voltage representative of the oscillator's ac output. U11D, CR1, CR2, R16 and R17 comprise a half-wave precision rectifier with a gain of 2. Capacitor C7 prevents dc offset at the oscillator output from altering the rectified value. The average voltage at TP2 is 1.087 times the rms value of the oscillator's output voltage. Thus, the output at TP3 (0.46 V rms) is the reference voltage (0.5 V) divided by 1.087 (plus 20-30 mV due to offsets in the rectifier bias network).

AGC Mechanism. The gain of U11B is controlled by the varying shunt-element resistance of control-FET Q1. Resistor R14 and Q1 in series allows a possible gain change from "times 1.0" to "times 3.1", which is sufficient to overcome the gain loss in the Wein-bridge circuit and permit oscillation.

The resistance of Q1 is controlled by varying the gate voltage. A more negative voltage on the Q1 gate increases (cuts off Q1) the drain to the source resistance, thereby reducing the gain of U11B.

The gate control voltage is supplied by the reference amplifier-integrator, U11C. Equilibrium is obtained when the integrated (averaged) output voltage from the detector equals the reference voltage (0.5 V) at U11.10. The ac output at TP3 will be within 1 dB of 0.46 V rms. A slight peak in response of approximately 0.1 dB occurs at 125 Hz due to the C7-R17 time constant.

4.2.4 Squarer.

U11A is a squarer-amplifier used as a digital-timing drive to achieve good synchronization of the digital circuitry with the analog signal. This provides a low-to-zero crossing error. U11A works open-circuited, similar to a comparator whose output swings beyond the CMOS threshold requirements.

4.2.5 Attenuator.

The output of the oscillator is fed to an attenuator stage where the 5 different levels (74 through 114 dB) are selected by the LEVEL switch (S1). The LEVEL switch acts as a stepped/shunt attenuator, where resistors R29-R32 shunt out the signal at R18.

The variable attenuator-control network — R19, R20, R21 and R54 — acts as part of the R29-R32 network, since there is always 1 resistor in the former network in parallel with the elements of the latter network. The first attenuator position gives a 6.025-dB attenuation of the signal at TP3; successive positions add 10 dB to the attenuation and should be within 0.10 dB of the correct value.

4.2.6 Gain-Control Stage

The purpose of the gain-control stage is to modify the level as required by the particular mode selected by the VARIABLE SPL switch (S2). There are 2 parts of this stage: the variable-gain setting (SPL ADJUST circuit) and the gain-shift amplifier (feedback-control circuit).

The SPL ADJUST control, R20, provides a variable-gain setting. This control is inoperative in the CALIBRATED SPL position of S2, since the signal is then selected by U13C. In the 5 VARIABLE SPL modes (**set fast/slow**, **fast**, **slow**, **set crest fctr**, **crest factor**) of S2, however, the signal is selected by U13D from the arm of the SPL ADJUST control. (Note that R19, R20, R21 and R54 are always part of the shunt attenuator.) Resistor R54 provides a "precise value" to the variable control, R20. The range of R20 is -2 to -14 dB re the value at U13C (but *not* below the continuous value at the ac output). U16B provides the inversion necessary to give the not-continuous logic control on U13D.

The gain-shift amplifier, U12A, is a self-feedback amplifier that shifts the nominal level to give the proper gain for the various operating modes. (For example, the gain must be considerably higher in the **crest factor** mode than in the other modes.) The net gain shift for various modes can be checked at TP4 in conjunction with the SPL ADJUST control (R20). Table 4-2 gives the net gain shifts at TP4 when R20 is set at its design center (-8 dB). (The values given in this table are for the frequencies that are interlocked by Jumper J1 for normal operation (see para 5.4), although U12A is designed to produce similar gain shifts at other frequencies also.) The tolerance for the gain shift from one mode to an adjacent mode (in Table 4-2) is ± 0.2 dB, except for the shift from **set crest fctr** to **crest factor**; this latter shift is important for the rms-accuracy test described in para 2.9.6, and should be 6.58 dB ± 0.1 dB.

Table 4-2

NET GAIN SHIFTS AT TP4

VARIABLE SPL (S2) Setting	Gain Shift* (dB)
CALIBRATED SPL	0
set fast/slow , fast , slow	10.1 - 8 = 2.1 (@ 1 kHz [†])
set crest fctr	13.1 - 8 = 5.1 (@ 2 kHz [†])
crest factor	19.7 - 8 = 11.7 (@ 2 kHz [†])

* Tolerance is ± 0.2 dB, except for shift from **set crest fctr** to **crest factor**, where shift is 6.58 dB ± 0.1 dB.

† Although U12A is designed to produce similar gain shifts at other frequencies, this frequency is specified by sound-level-meter standards and is interlocked by J1 for normal operation (see para 5.4).

4.2.7 Background-Level Amplifier.

The background-level amplifier, U12D, provides a precise decrease in level of 20 dB during the "off" time of the **fast** and **slow** modes. This is accomplished by switching the values of resistors in a ratio of 10:1 during the "on" time of the inverting amplifier U12D, which is then at unity gain.

U12D also provides an electrical version of the output signal to the AC OUTPUT jack, J3, via resistor R33 (this jack is shortable without affecting the transducer output). The ac output is flat versus frequency (± 0.2 dB) and is -6 dB re the oscillator output at 114 dB in the CALIBRATED SPL mode. Capacitor C11 blocks any dc signal that would cause glitches during switching of the background-control gates U13A and U13B.

4.2.8 Output Amplifier.

The current-source output amplifier (or transducer driver) consists of voltage amplifier U14, complementary current amplifiers Q3 and Q4, and resistors R29 and R50. This circuit serves 2 functions: it contains the individual level-calibration adjustment for each frequency, and it drives the output transducer that provides the acoustical signal to a sound-measuring instrument under test.

Diodes CR5 and CR6 provide bias for Q3 and Q4 to prevent crossover distortion. Capacitor C9 bootstraps the output to the base drive of Q3 for increased output-voltage swing.

Components R57, C12, R58 and C13 provide filtering to prevent large current surges from influencing the lower level stages of the calibrator. Components C10 and R51 prevent oscillation of the amplifier due to the transducer's inductive load at high frequencies. The transducer's inductive-load impedance at 1 kHz is $50\Omega \pm 5\%$.

The transducer is driven from a constant current source to avoid temperature effects of the transducer's copper coil. This constant current drive is achieved by sampling the transducer's current at R52. Keeping the voltage constant across R52 will, in effect, maintain a constant current in the transducer.

The sound-pressure level of the transducer's output signal is controlled by the gain of the amplifier and the input signal. The gain of the amplifier at 1 kHz is determined by the ratio of the transducer's impedance and R52 ($50/15.8 = 3.2 = 10.1$ dB) plus the ratio of R45 and R41 ($2.74/6.98 = 0.39 + 1 = 1.39 = 2.88$ dB) for a net gain of 13 dB at 1 kHz. The level of other frequencies is set by adjusting the feedback from 0 dB to -7.6 dB, giving a range of gain from -2.8 dB to +4.8 dB re 1 kHz.

4.3 DIGITAL CIRCUITS.





4.3.1 General.

The lower portion of Figure 6-4 is a block diagram of the digital circuits in the 1986, and Figure 6-7 is a schematic diagram of these circuits. The purpose of the digital circuits is to provide proper timing-control signals during the **fast**, **slow** and **crest factor** modes of operation; for all of these modes, the signal is reduced by 20 dB from "on" to "off." The timing signal in the **fast** mode has a 10% duty cycle to switch the output "on" for 200 ms and "off" for 1.8 s. The **slow**-mode signal has a 5% duty cycle to switch the output on for 500 ms and off for 9.5 s. In the **crest factor** mode, the signal is on for 5.5 ms and off for 19.5 ms.

The timing-control signals for the **fast**, **slow** and **crest factor** modes are routed from the digital to the analog section via the Output Control and Background Level lines. The timing is a function of the setting of 2 controls, the FREQUENCY switch (S3) and the VARIABLE SPL switch (S2); the signals for these 2 controls are conveyed via the Frequency Control Bus and the Calibrated-Variable SPL Control Bus.

Many of the logical functions are shared by the **fast**, **slow** and **crest factor** modes, with the particular logic configuration set by mode-control gates. The Output Control signal can be monitored at TP19, and the Background Level signal at TP20. Table 4-3 gives the logic status of these 2 signals for the various 1986 modes.

Table 4-3
DIGITAL OUTPUT VS MODE

Mode	Output Control Line (TP19)	Background Level Line (TP20)
CALIBRATED SPL	1	0
set fast/slow	1	0
fast*		
slow†		
set crest fctr	1	0
crest factor‡		0

*0.2-s transition every 2 s.

†0.5-s transition every 10 s.

‡5.5-ms transition every 25 ms.

The FREQUENCY switch (S3) and the VARIABLE SPL switch (S2), in conjunction with U21B and U21C, serve to lock the frequency to 1 kHz or 2 kHz in certain modes. In the **fast** and **slow** modes, the tone-burst frequency is locked into 1 kHz; in the **crest factor** mode, the tone-burst frequency is locked into 2 kHz. Although these are the preset tone-burst frequencies for these modes, the frequency-interlock jumper (J1) can be repositioned to allow a different tone-burst frequency to be selected (refer to para 5.4).

4.3.2 Timing.

The basic input for the timing signals is derived from the oscillator through buffer U10E; the oscillator signal is shaped to a square wave by squarers U10 and U11. As described above, the 1-kHz and 2-kHz frequencies are interlocked for the tone-burst modes. For the non-interlocked frequencies, the "on" time duration and period is proportional to the frequency selected.

4.3.3 Calibrated-SPL and Set Modes.

The signal to the output-control line is always "on" for the CALIBRATED SPL, set fast/slow and set crest fctr modes; this is sensed by OR gate U21A. (Note that the VARIABLE SPL switch makes it possible to select only 1 of these 3 modes at any time.) The positive output from U21A forces the output of NOR gate U6C low, and this signal is inverted by U10 to become the positive output-control signal. This positive signal also forces the output of NOR gate U6D low, and this becomes the background-level signal.

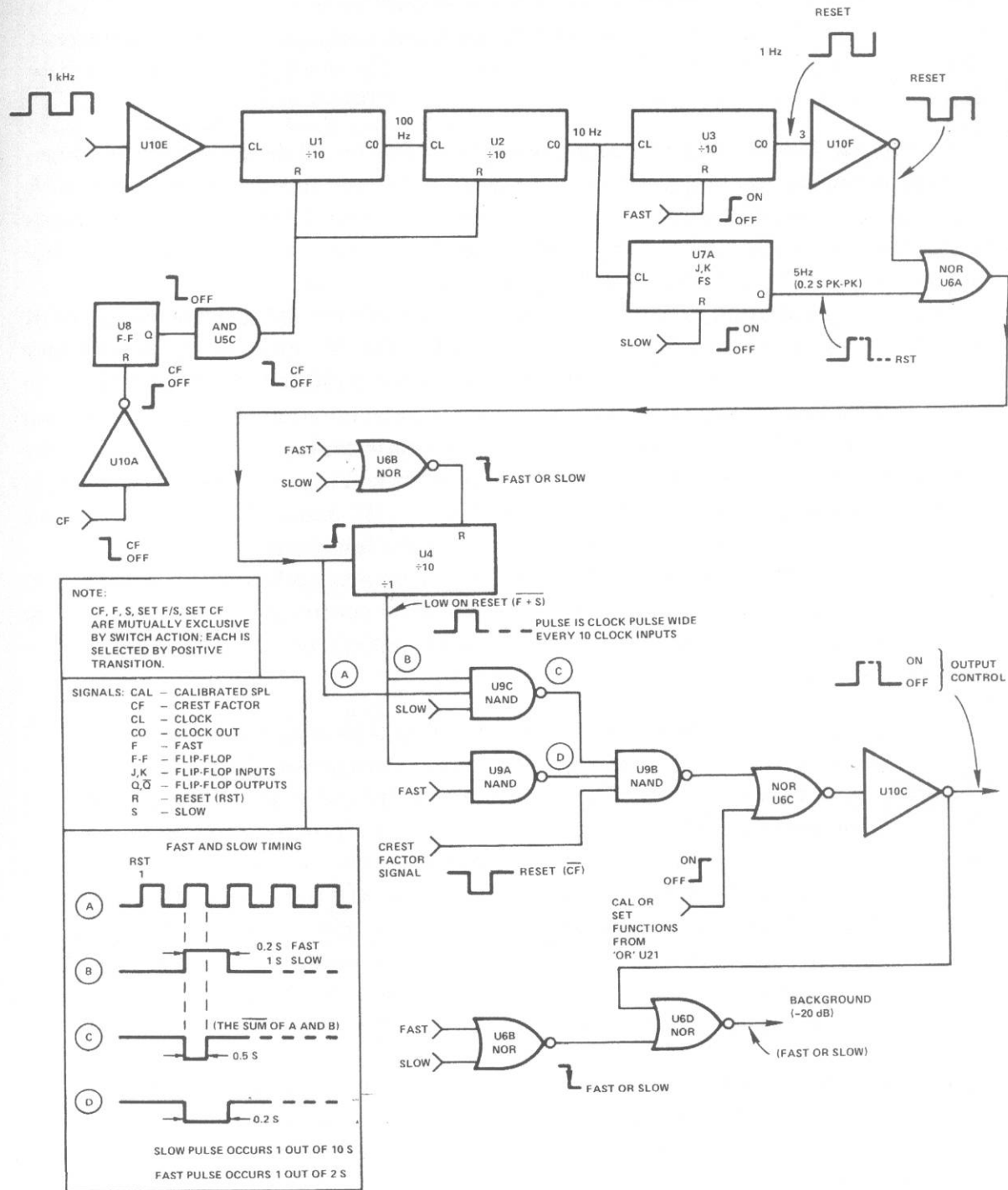

Figure 4-1. Fast/Slow timing diagram.

4.3.4 Fast and Slow Modes.

(Figure 4-1)

Input-Divider Chain. In the **fast** and **slow** modes (or, whenever the **crest factor** mode is *not* selected), the signal from buffer U10E is first divided by 100 by the programmable input-divider chain U1 and U2. When either the **fast** or **slow** mode is selected, the **crest factor** signal at U10A becomes positive and resets the "Q" of U8 to low. This logic 0 forces the output of AND gate U5C low, and this output is the reset line of dividers U1 and U2. Since the interlocked frequency for the **fast** and **slow** modes is 1 kHz, the $\div 100$ output frequency is 10 Hz (100-ms period).

Fast-Signal Timing. When the **fast** mode is selected, the U3 divider-reset line is high, thereby inhibiting the output (which goes high). The reset line of flip-flop clock U7A is low (since it is the "slow" signal when it is low), and the 10-Hz divider-chain signals are presented to the input of this clock. The Q⁻ of U7A therefore has a signal frequency that is 1/2 the flip-flop input, or 5 Hz (200-ms period).

The $\div 2$ output from U7A and an inverted output from U3 are selected by NOR gate U6A, resulting in a 5-Hz signal at the input of the U4 clock (point **A** in Figure 4-1). U4 is free to count in the **fast** and **slow** modes (U6B sets the reset line low in these modes), and its logic-1 output is high for 1 clock duration out of every 10 input cycles, or for 200 ms every 2 s (10x0.2 s). This basic timing signal is selected by the **fast** gate, U9A; it is then passed through the **crest-factor** gate, U9B, and the CALIBRATED SPL (continuous) and "set" (pulse) gates, U6C and U10C. The output signal from U10C is used to control the analog output in the **fast** mode.

Note that U6B is selected by either the **fast** or **slow** mode so that the background-level-control gate, U6D, responds to the output-level control signal. The background level is low when the output level is high, and the background level is high when the output level is low.

Slow-Signal Timing. For the **slow** mode, flip-flop U7A is deselected and divider U3 is free to count with an output of 1 Hz. The same $\div 100$ signal of the U1 and U2 that is used for the **fast** mode is further divided by 10 by U3 and then routed through gate U6A. The net signal at **A** is therefore a continuous 1 Hz. In a manner different from the **fast** mode, this 1-Hz signal is applied to both driver U4 and slow-selector gate U9C. Thus, the output at **D** is the inverted sum of **A** and **B** (see Figure 4-1), such that the period is 10 s (10x1 s); but the duration is 1/2 of a clock cycle, or 500 ms. The net result is a 0.5-s signal every 10 s, which is the timing signal for the **slow** mode. The signal at **C** is gated through U9B, U6C and U10C and then passed on to the output-control line in the same manner as the **fast** signal.

4.3.5 Crest-Factor Mode.

(Figure 4-2)

The operation of the **crest factor** timing is somewhat more complicated than that for **fast** and **slow**. Flip-flop U8A is set free to divide in the **crest factor** mode, since the reset line is low. AND gate U5D also selects the timing signal that comes from the Q of U7B. Dividers U1 and U2 together function as a $\div 50$ clock. Through a recognition scheme on their outputs, U2 and U1 are reset by a combination of the input signal at **A** and the Q output of flip-flop U8A at **G**; this results in the timing signal at the output of the crest-factor-select gate U5D. The reset will occur on the first positive clock cycle at **A** once **G** is set high, and will last 1/2 of a clock cycle.

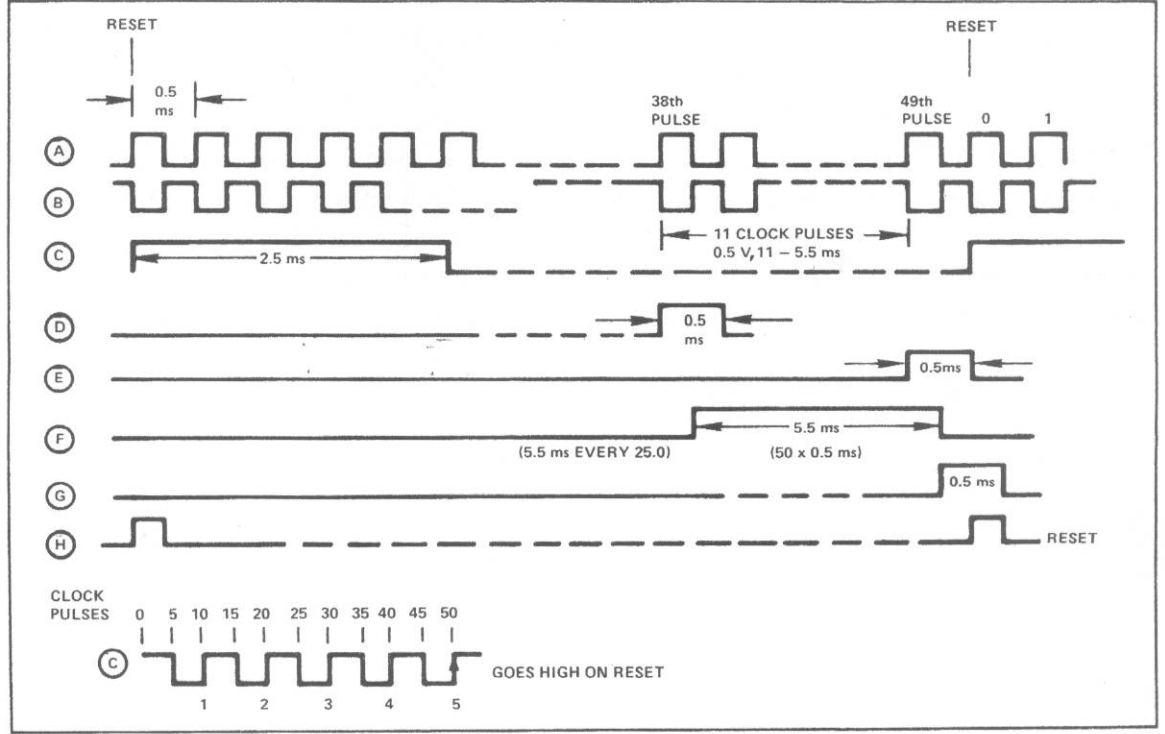
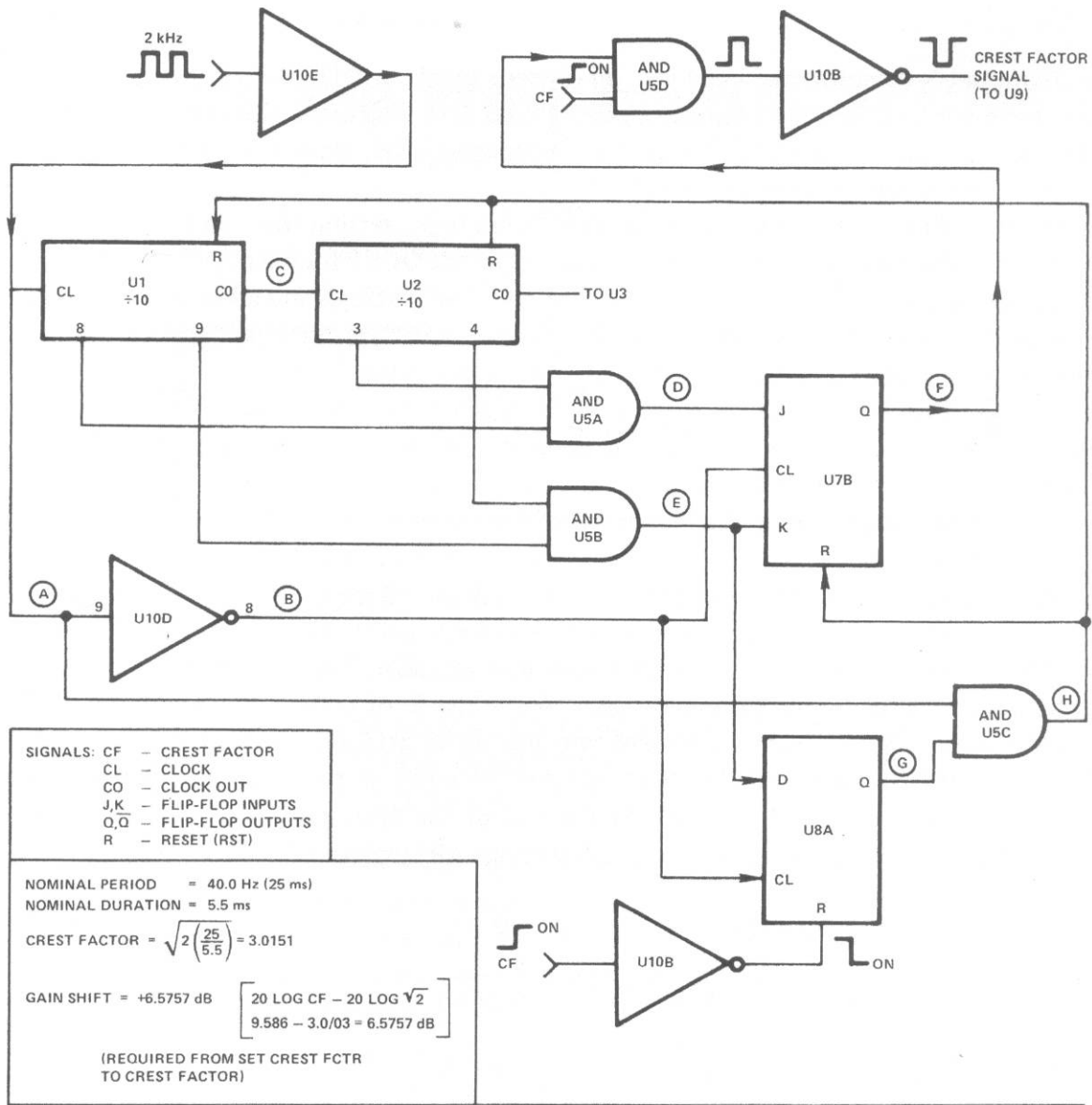

Figure 4-2. Crest-Factor timing diagram.

Assuming a reset has just occurred, all outputs on U1 and U2 will be low. Therefore the outputs of AND gates U5A and U5B will be low. Thus, the Q output of flip flop U7B will be low as the $\overline{\text{CLOCK}}$ signal at (B) toggles U7B. Note that flop-flop U7B is reset by the common reset of U1 and U2.

On the 38th clock cycle, the signal at (D) goes high, setting the J input of J/K flip flop U7B. The next 1/2 cycle of the signal at (B) ($\overline{\text{CLOCK}}$) transfers the high J input to the Q output at (F). This is the start of the "on" cycle of the crest-factor control line. After the 38th cycle, the signal at (D) goes low, but the high flip-flop J input remains stored and continues to be transferred to the output.

On the 49th positive clock cycle at (A) and gate U5B, the output at (E) goes high. Half of a clock cycle later, the $\overline{\text{CLOCK}}$ signal at (B) transfers the signal at (E) from flip-flop U7B K input to the output, making the signal at (F) go low. The difference between 38 and 49 cycles is the "on time" of the output signal:

$$49 - 38 = 11 \text{ cycles}, 11 \times 1/2000 \text{ Hz} = 11 \times 0.5 \text{ ms} = 5.5 \text{ ms}$$

The system is reset 1/2 of a clock cycle later by U8A. The 49th clock-recognition cycle at (E) is also the data input of U8A. While the Q of U7B is going low, the same clock cycle at (B) ($\overline{\text{CLOCK}}$) is transferring the signal at (E) to the Q output of U8A. This sets up AND gate U5C for the next positive cycle of the clock at (A) to set the common reset line at (H) positive. At the end of the 49th cycle, the system is reset and ready to recycle. The total period is 0 through 49 cycles, or 50 cycles total:

$$50 \times 1/2000 \text{ Hz} = 50 \times 0.5 \text{ ms} = 25 \text{ ms (or 40 Hz)}$$

$$\text{since, CREST FACTOR} = \sqrt{2 \times \text{Period/Duration}}$$

$$\text{then, CREST FACTOR} = \sqrt{2 \times 25/5.5} = 3.0151$$

The signal at the output of the crest-factor-select gate, U5D, is inverted by U10B and inserted in the output-control chain at the fast-slow-crest-factor gate, U9B. The signal is then routed through the pulse-or-continuous select gates U6C and U10C.

Since both the **fast** and **slow** signals are low (deselected), gates U9A and U9C inhibit any signals from the fast-slow circuitry and allow U9B to pass the **crest factor** control signal on to U6C and U10C. Note that deselection of NOR gate U6B inhibits the background-level control gate, U6D, causing it to be always low. In the **fast** and **slow** modes, the output of U6D has the opposite polarity of the **crest factor** control signal discussed above. This signal, from U6D, is used to control the background-level amplifier (U12D) in the analog section.

Service and Maintenance – Section 5

CAUTIONS

The service instructions in this section should be performed by qualified personnel only.

CAUTION 	THE FOLLOWING COMPONENTS REQUIRE SPECIAL HANDLING FOR STATIC PROTECTION U1 through U11 and U13 through U21; Q1
---	--

Service personnel should observe the following precautions whenever handling the circuit board or any of its components listed in the symbol above. (This symbol is also included on the etched-board and schematic drawings in Section 6.)

HANDLING PRECAUTIONS FOR ELECTRONIC DEVICES SUBJECT TO DAMAGE BY STATIC ELECTRICITY

Place instrument to be serviced, spare parts in conductive (anti-static) envelopes or carriers, hand tools, etc on a work surface defined as follows. The work surface, typically a bench top, must be conductive and reliably connected to earth ground through a safety resistance of 250 k Ω (min) to 500 k Ω (max). Also for personnel safety, the surface must NOT be metal; a resistivity of 30 k Ω per square is recommended. Avoid placing items on insulators, such as books, paper, rubber pads, plastic bags, or boxes.

Ground the frame of any line-powered equipment, test instruments, lamps, drills, soldering irons, etc., directly to earth ground and be sure they have rubber feet or other means of insulation from the work surface. The instrument being serviced should be similarly insulated while grounded through the power-cord ground wire, but must be connected to the work surface before, during, and after any disassembly or other procedure in which the line cord is disconnected. (Use a clip lead.)

Exclude any hand tools and other items that can generate a static charge. (Examples of forbidden items are non-conductive plunger-type solder suckers and rolls of vinyl electrical tape.)

Ground yourself reliably, through a resistance, to the work surface; use for example a conductive strap or cable with a wrist cuff. (Suitable personnel-grounding devices are commercially available.) The cuff must make electrical contact directly to your skin; do NOT wear it over clothing. Resistance between skin contact and work surface must be 250 k Ω (min) to 1 M Ω (max).

If any circuit boards or IC packages are to be stored or transported, enclose them in conductive envelopes and/or carriers. Remove the items from such envelopes only with the above precautions; handle IC packages without touching the contact pins.

Avoid circumstances that are likely to produce static charges, such as wearing clothes of synthetic material, sitting on a plastic-covered or rubber-footed stool (particularly while wearing wool), combing your hair, or making extensive erasures. These circumstances are most significant when the air is dry.

When testing static-sensitive devices, be sure dc power is on before, during and after application of test signals. Be sure all pertinent voltages are switched off while boards or components are removed or inserted, whether hard-wired or plug-in.

5.1 CUSTOMER SERVICE.

The warranty (at the front of the manual) attests the quality of materials and workmanship in GenRad products. If malfunction does occur, GenRad service engineers will assist in any way possible. If the difficulty cannot be eliminated by use of the following service instructions, please write or phone the nearest GenRad service facility (see back page), giving full information of the trouble and the steps taken to remedy it. Describe the instrument by name, catalog number, serial number, and ID (lot) number if any. (Refer to front and rear panels.)

5.2 INSTRUMENT RETURN.

5.2.1 Returned Material Number.

Before returning an instrument to GenRad for service, please ask the nearest office for a "Returned Material" number. Use of this number in correspondence, and a tag tied to the instrument, will ensure proper handling and identification. After the initial warranty period, please avoid unnecessary delay by indicating how payment will be made; i.e., send a purchase-order number.

5.2.2 Packaging and Cushioning.

To safeguard the instrument during storage and shipment, please use packaging that is adequate to protect it from damage, i.e., equivalent to the original packaging. Any GenRad field office can advise or provide packing material for this purpose. Contract packaging companies in many cities can provide dependable custom packaging on short notice.

Cover the painted surfaces of the instrument with protective wrapping paper or plastic film. Pack the instrument securely in a strong, protective, corrugated container with a minimum bursting test of 20 kg/cm² (275 lb/in.²). Place urethane-foam or plastic-air-cell cushioning along all surfaces of the instrument. Ensure a snug fit. Mark the box "Delicate Instrument" and seal it with strong tape.

5.3 PERFORMANCE VERIFICATION.

The following procedure is intended as a quick performance check of the 1986, and is distinct from the test and calibration procedures in para 5.6 that require accuracy traceable to the National Bureau of Standards. A sound-level meter such as the GR 1982 Precision Sound-Level Meter, or its equivalent, should be used for this performance test.

a. The calibration of the 1982 should first be checked, and adjusted if necessary, using another calibrator with a known accuracy correct to within ± 0.5 dB. A GR 1987, GR 1562, or GR 1567 can be used for this purpose. To calibrate the 1982, set its controls as follows:

Power Switch ON
 DIGITAL DISPLAY CONT
 OCTAVE FILTER FREQ (Hz) 1 kHz
 dB RANGE 70 – 120
 DETECTOR FAST

b. Set the controls on the calibrator being used to correspond with the 1982 controls that were set in step a. Install a 1/2-in. microphone adaptor on the transducer of the calibrator, and then insert the transducer and adaptor over the microphone of the 1982.

c. Observe the 1982 digital display, and adjust its CAL control for a reading of exactly 114.0 dB. The 1982 is now accurately calibrated to within ± 0.5 dB.

d. Insert the 1/2-in. microphone adaptor (P/N 1987-7061) in the transducer cavity of the 1986 under test.

e. Place this transducer-adaptor assembly over the microphone of the 1982, and select the following on the 1986.

FREQUENCY 1 kHz
 LEVEL 114 dB
 VARIABLE SPL CALIBRATED SPL

f. Observe the reading on the 1982; it should be 114 dB, ± 0.5 dB; readjust CAL control for exactly 114 dB before proceeding.

g. Select the other 5 FREQUENCY positions on the 1986 and, in each case, select the corresponding frequency on the 1982 OCTAVE FILTER FREQ control. Observe the reading at each frequency; acceptable tolerances are indicated in Table 5-1

Table 5-1
 CALIBRATION TOLERANCES FOR VARIOUS FREQUENCIES

1986 Frequency (Hz)	1982 Octave Filter Frequency (Hz)	Acceptable Reading on 1982 Digital Display* (dB)
1 k	1 k	Adjust 1982 CAL control for 114.0 dB reference.
125	125	114.0 \pm 1.5
250	250	114.0 \pm 1.5
500	500	114.0 \pm 1.5
2 k	2 k	114.0 \pm 1.5
4 k	4 k	114.0 \pm 2.0

* Refer to Table A in the Condensed Operating Instructions for microphone corrections that must be added to the 1982 reading before comparing it to the values below.

h. Return the 1986 FREQUENCY switch to 1 kHz, and the 1982 OCTAVE FILTER FREQ switch to 1 kHz. The 1982 should still indicate 114.0 dB; if not, readjust its CAL control.

i. Select the other 4 LEVEL positions on the 1986 and, in each case, select the corresponding 1982 dB RANGE indicated in Table 5-2. Observe the reading for each of the 4 settings of the 1986 LEVEL control; acceptable tolerances are indicated in Table 5-2.

Table 5-2
CALIBRATION TOLERANCES FOR VARIOUS LEVELS

1986 Level (dB)	1982 dB Range (dB)	Acceptable Reading on 1982 Digital Display* (dB)
114	70 – 120	Adjust 1982 CAL control for 114.0 dB reference.
104	70 – 120	104.0 ± 0.5
94	50 – 100	94.0 ± 0.6
84	50 – 100	84.0 ± 0.5
74	30 – 80	74.0 ± 0.6

*See footnote, Table 5-1.

j. Return the 1982 dB RANGE control to the 70 – 120 dB position, and the 1986 LEVEL control to 114 dB. Set the 1982 OCTAVE FILTER FREQ switch to WTG, and the WEIGHTING switch to C.

k. Set the 1986 VARIABLE SPL control to **set fast/slow**. Turn the SPL ADJUST control fully clockwise, and note the 1982 indication; it should be greater than 118.0 dB. Now turn the SPL ADJUST fully counterclockwise, and again note the 1982 indication. The difference between the 2 readings should be at least 11.0 dB.

l. Set the SPL ADJUST control for an indication of 116.0 dB on the 1982.

m. Set the VARIABLE SPL switch to **fast**. The output of the 1986 now contains 1-kHz tone bursts; each burst has a 200-ms duration once every 2 s. The 1982 indication should drop to 96.0 ± 1.0 dB during the "off" time, and rise to 115.0 ± 1.0 dB during the "on" time.

n. Set the 1982 DETECTOR switch to SLOW and the 1986 VARIABLE SPL switch to **slow**. The output of the 1986 now contains 1-kHz tone bursts; each burst has a 500-ms duration once every 10 s. The 1982 indication should drop to 96.0 ± 1.0 dB during the off time, and rise to 112.0 ± 1.0 dB during the on time.

o. Return the 1982 DETECTOR switch to FAST and the dB RANGE switch to 50 – 100 dB. Set the 1986 LEVEL control to 94 dB and the VARIABLE SPL switch to **set crest fctr**.

p. Adjust the SPL ADJUST control for an indication of 98.0 dB on the 1982.

q. Set the VARIABLE SPL switch to **crest factor**. The output of the 1986 now contains 2-kHz tone bursts at a 40-Hz repetition rate; each burst has a 5.5-ms duration with a crest factor of 3. The 1982 indicator should still indicate 98.0 ± 0.5 dB.

5.4 FREQUENCY INTERLOCK.

When the 1986 is shipped from the factory, an internal jumper (J1) is set for a "frequency interlock" mode of operation. Under this condition, the FREQUENCY switch is functional only in the CALIBRATED SPL position of the VARIABLE SPL control. In each of the other 5 VARIABLE SPL modes, a frequency of either 1 kHz or 2 kHz is automatically generated as specified by the standards for testing sound-measuring instruments. A 1-kHz tone-burst signal is generated in the **fast** and **slow** modes, and a 2-kHz tone-burst signal in the **crest factor** mode.

It is possible to increase the test capability of the 1986 by repositioning the interlock jumper, J1, to its non-interlock position. In the "frequency non-interlock" mode, a full selection of frequencies from 125 Hz to 4 kHz is possible in all 6 VARIABLE SPL positions. This makes possible a wide variety of tone-burst on-and-off times. These signals can be used for purposes other than the standards-specifications testing mentioned above, where only the 1-kHz signal was available in the **fast** and **slow** modes and only the 2-kHz signal in the **crest factor** mode. Table 5-3 lists the on and off durations and the periods for the 3 tone-burst modes (**fast**, **slow**, and **crest factor**) when jumper J1 is in the non-interlock position.

In order to change interlock jumper J1 to its non-interlock position, it is first necessary to remove the cover from the 1986; refer to para 5.5 for this disassembly procedure. The location of jumper J1 is shown in Figure 5-2. It must be unplugged from the board, rotated 180°, and then plugged back into the board to set the 1986 for the non-interlock mode of operation. (When the dot on the top of the J1 connector is adjacent with the dot on the board, the jumper is in its "frequency interlock" position; reversing this orientation establishes the "frequency non-interlock" position.)

If at any time the position of the non-interlock plug is uncertain, it can be easily determined by setting the 1986 VARIABLE SPL control to **set fast/slow** position; in this mode, the acoustic output of the 1986 can be audibly monitored as the FREQUENCY switch is changed. In the interlock mode, the FREQUENCY switch has no effect on the 1986 output, since a constant frequency of 1 kHz is automatically generated. In the non-interlock mode, the output frequency will audibly change as the FREQUENCY control is switched to different positions.

5.5 DISASSEMBLY.

Disassembly of the 1986 essentially consists of removing the knobs and top black cover to gain access to the circuit board; this would normally only be required for troubleshooting purposes, recalibration, or repositioning of the frequency-interlock jumper J1 (discussed in the preceding paragraph).

To remove the cover from the 1986, proceed as follows:

- a. First remove the 4 black knobs by grasping each one firmly and pulling it off of its shaft. It is not necessary to remove the metal inserts that are exposed once the knobs are removed, as the cover can be removed with them in place.
- b. Remove the 6 Phillips-head screws on the underside of the instrument as noted in Figure 5-1.
- c. Grasp the cover and remove it from the instrument by sliding it over the switch shafts. Figure 5-2 is a view of the circuit board (P/N 1986-4700) as it appears in the instrument once the cover is removed.

Table 5-3
TONE-BURST DURATIONS
IN THE NONINTERLOCK MODE

Frequency Setting (Hz)	Fast Mode			Slow Mode			Crest-Factor Mode		
	On-Time of Tone Burst (s)	Off-Time* of Tone Burst (s)	Total Period (s)	On-Time of Tone Burst (s)	Off-Time* of Tone Burst (s)	Total Period (s)	On-Time of Tone Burst (ms)	Off-Time* of Tone Burst (ms)	Total Period (ms)
125	1.6	14.4	16.0	4.0	76.0	80.0	88	312	400
250	0.8	7.2	8.0	2.0	38.0	40.0	44	156	200
500	0.4	3.6	4.0	1.0	19.0	20.0	22	78	100
1000†	0.2†	1.8†	2.0†	0.50†	9.5†	10.0†	11†	39	50
2000	0.1	0.90	1.0	0.25†	4.75	5.0	5.5†	19.5†	25†
4000	0.05	0.45	0.5	0.125†	2.375	2.5	2.75	9.75	12.5

*Off-Time represents a 20-dB drop from the on-time.

† Denotes normal conditions for the interlock mode.

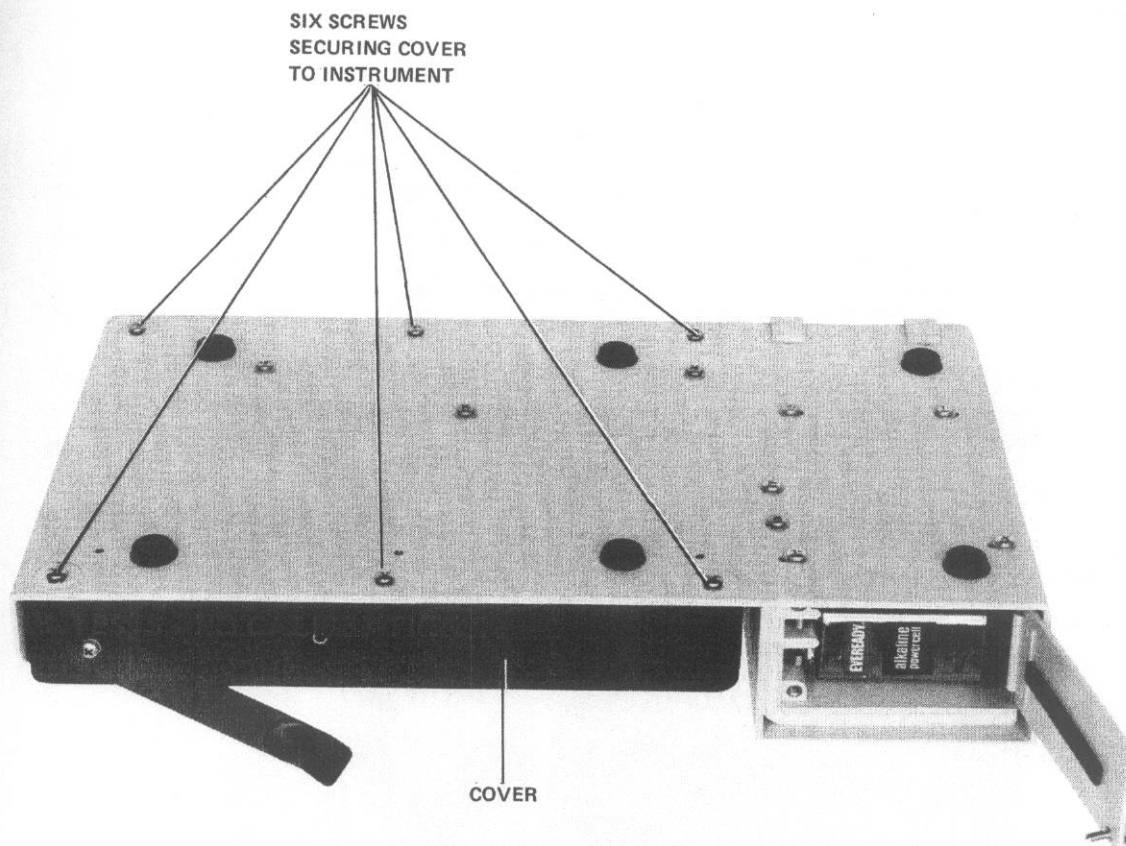

Figure 5-1. Removal of cover.

CAUTION

Observe the **HANDLING PRECAUTIONS** at the beginning of this section whenever handling the circuit board or any of its components subject to static electricity.

d. The cover and knobs can be reinstalled in the reverse order of steps a, b, and c. When replacing the cover, make sure that its edge is fitted to the gasket through which the transducer and battery cables pass. There are grooves in these gaskets to accommodate the edge of the cover.

5.6 TESTS AND CALIBRATIONS.

CAUTION

The following procedures are intended for an experienced technician.

The following procedures should be performed after an instrument has been repaired or when the evaluation of para 5.3 (performance verification) indicates that the instrument may not be functioning according to specifications. Before performing this calibration, the top cover must be removed from the instrument to allow access to test points and calibration adjustments (refer to the disassembly procedure in para 5.5).

A list of recommended test equipment is given in Table 5-4. Figure 5-2 shows the locations of test points and calibration potentiometers that will be used for the following procedures.

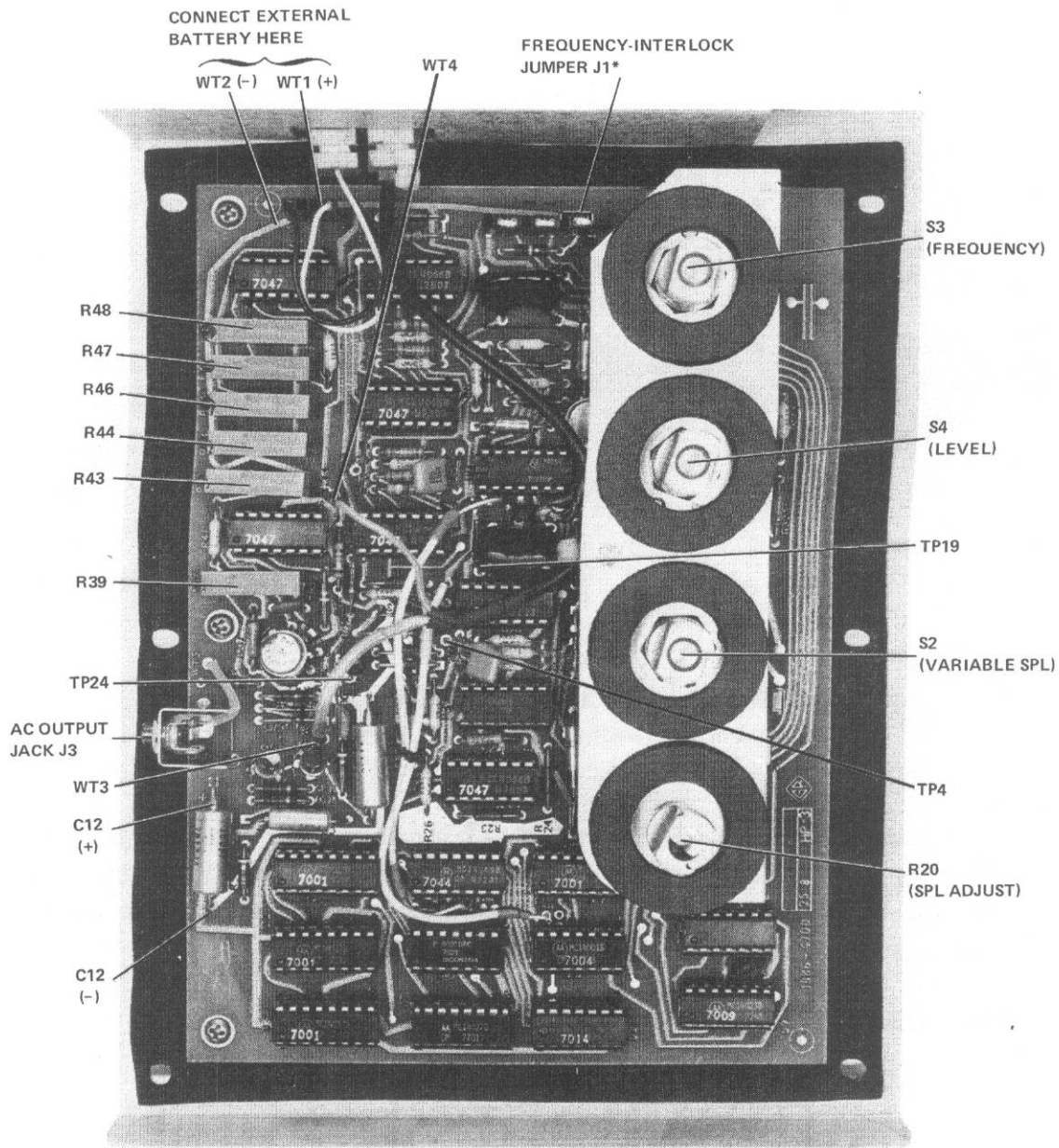

*DOT ON CONNECTOR IS ADJACENT TO DOT ON BOARD FOR "FREQUENCY INTERLOCK" MODE; REVERSE THIS ORIENTATION FOR "FREQUENCY NON-INTERLOCK" MODE.

Figure 5-2. Circuit-board (P/N 1986-4700) test points and calibration potentiometers.

Table 5-4
REQUIRED TEST EQUIPMENT

Equipment	Requirements	Recommended*
Capacitor	100 pF, 25 Vdc, $\pm 10\%$.	
Distortion Analyzer	Distortion down to 1%; voltage range 30 μ V to 30 V.	Hewlett-Packard 334A
Frequency Counter	General purpose; dc; frequency to 50 MHz.	GR 1192
Patch Cord	Double-banana plug (3/4-in. spacing) each end.	GR 274-NP
Patch Cord	Double-banana plug (3/4-in. spacing) to clip leads.	
Patch Cord	Double-banana plug (3/4 in. spacing) to miniature-phone plug (0.097-in. diameter).	GR 1560-P77
Patch Cord	Double-banana plug (3/4-in. spacing) to BNC (male).	GR 1560-P79
Patch Cord (2)	BNC (male) to clip leads.	
Power Supply	0 – 12 Vdc.	Hewlett-Packard 6213A
Resistor	47 k Ω , 1/8 W, $\pm 5\%$.	
Resistor	51 Ω , 1/8 W, $\pm 5\%$.	
Voltmeter, Digital	General-purpose; ac/dc.	Data Precision 3400
VOM	100-mA range.	Ballantine 323 VTVM

*Or equivalent.

5.6.1 Battery.

a. Make the setup shown in Figure 5-3. The power supply can be connected directly to the circuit board at WT1 (+) and WT2 (–) if the 1986 cover is removed (see Figure 5-2).

NOTE

When the cover is not removed, connections must be made to the battery terminals.

b. Set the 1986 as follows:

FREQUENCY 1 kHz
 LEVEL 114 dB
 VARIABLE SPL CALIBRATED SPL

c. Adjust the power-supply output for a 9-V indication on the DVM. Current drain from the 1986 is typically 15 to 20 mA.

d. Slowly decrease the output voltage from the power supply, and note the voltage at which the audible output from the 1986 cuts out. Typically this should occur at 7.0 ± 0.2 V.

e. Slowly increase the output voltage from the power supply until the 1986 turns back on, and note this voltage. This should occur at a voltage approximately 0.2 V above the cut-out voltage noted in step d above.

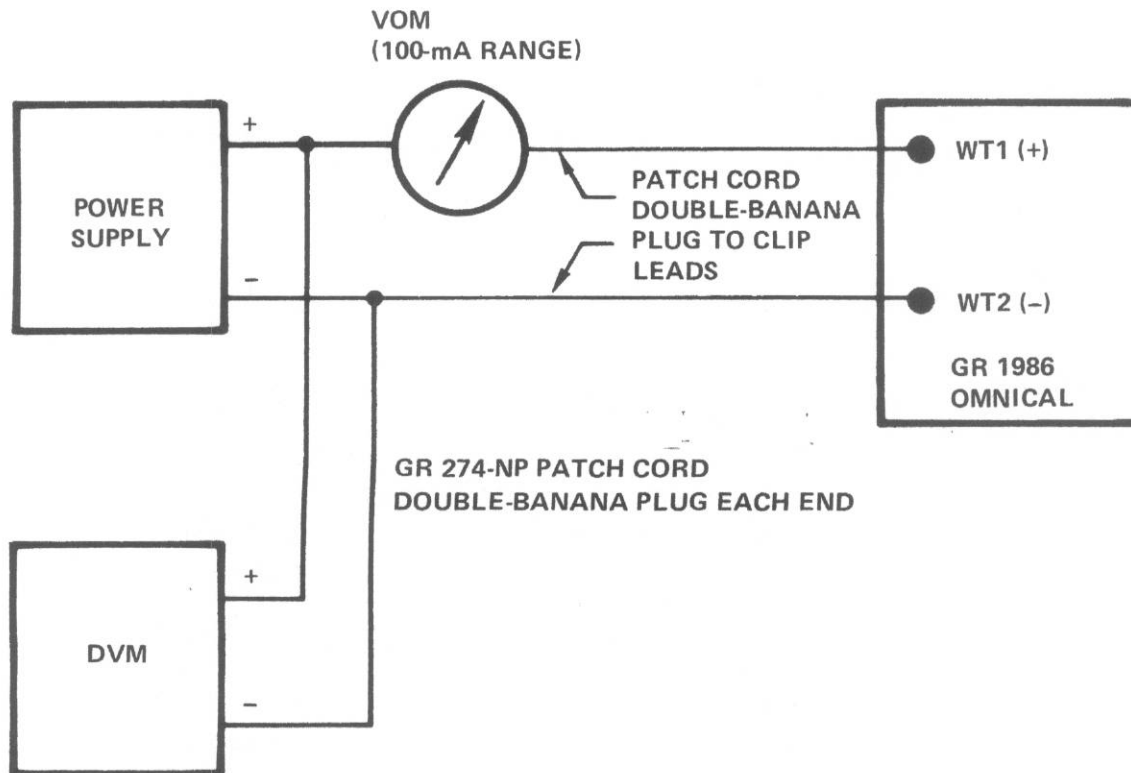

Figure 5-3. Test setup for battery check.

f. Remove the VOM from the setup and adjust the power-supply output to 7.5 V for the remaining tests.

5.6.2 AC Output.

The following procedure is for checking the level and distortion of the 1986 AC OUTPUT:

a. Connect the DVM (set to AC) to the 1986 AC OUTPUT connector using the GR 1560-P77 Cable.

b. Set the 1986 as follows:

FREQUENCY	1 kHz
LEVEL	114 dB
VARIABLE SPL	CALIBRATED SPL

c. The DVM should indicate an ac-output level of 230 mV \pm 23 mV.

d. On the 1986, change the VARIABLE SPL switch to **set fast/slow**.

e. Set the 1986 SPL ADJUST control for an indication of 0.500 V on the DVM.

f. Connect the 1986 AC OUTPUT to the HP-334A instead of to the DVM. The distortion should measure less than 1%.

5.6.3 Output Level to Transducer.

CAUTIONS

This test should be performed only if it is impossible to adjust the acoustical output to its proper level as described in para 5.6.10.

Once any adjustment of R39 has been made, the acoustical calibration of the 1986 is no longer valid.

a. Connect the DVM (set to AC) between WT3 (with transducer connected) and ground on the 1986. The connection to ground can be made on the negative side of C12, which is adjacent to the AC OUTPUT connector (refer to Figure 5-2).

b. Set the 1986 as follows:

FREQUENCY	1 kHz
LEVEL	114 dB
VARIABLE SPL	CALIBRATED SPL

c. Adjust the potentiometer, R39 (see Figure 5-2), fully clockwise and fully counterclockwise; note the voltage indication on the DVM at each setting of the potentiometer. The maximum-to-minimum voltage swing should be from 1.32 ± 0.20 V to 0.420 ± 0.06 V. Failure to meet the above voltages indicates either a defective transducer or 1986 circuit. In order to determine if the transducer is defective, replace the transducer with a $51-\Omega$ resistor across WT3 and WT4. If the maximum-to-minimum voltage swing is not within the specified range, then the transducer is defective. Otherwise, the 1988 circuitry is defective.

5.6.4 Attenuator Accuracy.

a. The DVM should remain, as previously connected in para 5.6.3, between WT3 and ground.

b. Set the 1986 as follows:

FREQUENCY	any setting (1 kHz is automatically generated in set fast/slow mode)
LEVEL	114 dB
VARIABLE SPL	set fast/slow

c. Set the SPL ADJUST control for an indication of 1.000V on the DVM.

d. Change the 1986 LEVEL control to the positions noted in Table 5-5. The voltage indicated on the DVM should be within the specified range.

5.6.5 Frequency.

a. Connect the GR 1192 Frequency Counter to the 1986 AC OUTPUT connector using the GR 1560-P79 Cable.

Table 5-5

VOLTAGE READINGS FOR ATTENUATOR-ACCURACY CHECK

1986 Level (dB)	DVM Voltage (mV)
114	reference*
104	313.0 – 319.4
94	99.0 – 101.0
84	31.3 – 31.9
74	9.90 – 10.1

* Reference voltage is 1.000 V.

b. Set the 1986 as follows:

FREQUENCY as noted below
 LEVEL 114 dB
 VARIABLE SPL CALIBRATED SPL

c. Select the 1986 FREQUENCY as noted in Table 5-6; the frequency indication on the 1192 must be within the range shown.

Table 5-6

FREQUENCY-CHECK READINGS

1986 Frequency Setting (Hz)	1192 Frequency Indication (Hz)
125	122.1 – 129.7
250	243.7 – 258.7
500	486.2 – 516.2
1,000	970 – 1,030
2,000	1,935 – 2,054
4,000	3,862 – 4,100

d. Set the 1986 as follows:

FREQUENCY 4 kHz
 LEVEL 114 dB
 VARIABLE SPL **set fast/slow**
 SPL ADJUST fully counterclockwise

e. The 1192 counter should indicate a frequency of 1000 ± 30 Hz. If the 1000-Hz frequency is not indicated, it is likely that either the 1986 is in the non-interlock mode, or the frequency circuitry of the 1986 is defective. Refer to para 5.4 for the procedures to change the frequency-interlock mode.

f. Set the 1986 as follows:

FREQUENCY any setting (2 kHz is auto-
matically generated in **set crest**
fctr mode)
LEVEL 104 dB
VARIABLE SPL **set crest fctr**

g. The 1192 counter should indicate a frequency of 2000 Hz, plus 54 Hz or minus 65 Hz.

5.6.6 SPL-Adjust Range.

In Set Fast/Slow Mode.

a. Connect the HP-334A to the 1986 AC OUTPUT connector using the GR 1560-P77 Cable.

b. Set the 1986 as follows:

FREQUENCY 1 kHz
LEVEL 114 dB
VARIABLE SPL CALIBRATED SPL

c. Set the HP-334A as follows:

FUNCTION SET LEVEL
METER RANGE SET LEVEL 100

d. Adjust the HP-334A SENSITIVITY vernier control for a reference reading of -6.0 dB on its meter.

e. Change the 1986 VARIABLE SPL control to **set fast/slow**.

f. Set the 1986 SPL ADJUST fully clockwise and fully counterclockwise, and note the reading on the 334A meter in each case. The level should be adjustable down to at least -9.5 dB and up to at least +1.5 dB.

NOTE

This represents an adjustment over an 11-dB span from 0.154 V to 0.545 V about the nominal ac output voltage of 0.23 V at 114 dB.

In Set Crest Fctr Mode:

a. Set the 1986 as follows:

FREQUENCY 1 kHz
LEVEL 104 dB
VARIABLE SPL CALIBRATED SPL

- b. On the HP-334A, set the METER RANGE to SET LEVEL 30. Adjust the HP-334A SENSITIVITY vernier control for a reference reading of -9.0 dB on its meter.
- c. Change the VARIABLE SPL control on the 1986 to set crest fctr.
- d. Set the 1986 SPL ADJUST fully clockwise and fully counterclockwise, and note the reading on the 334A meter in each case. The level should be adjustable down to at least -9.5 dB and up to at least $+1.5$ dB.

NOTE

This represents an adjustment over an 11-dB span from 68.6 mV to 243 mV about the nominal ac output voltage of 72.7 mV at 104 dB.

5.6.7 Timing Functions.

- a. Make the setup shown in Figure 5-4 in the following sequence (refer to Figure 5-2):

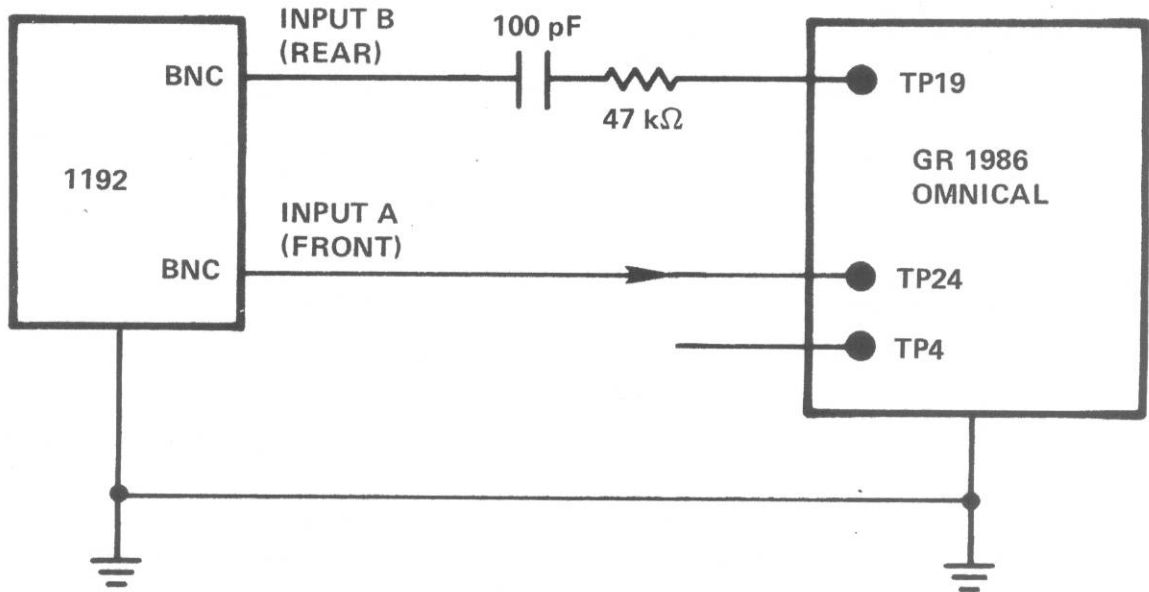

Figure 5-4. Test setup for timing-functions check.

- Connect Input B to TP19 through a 100-pF capacitor and a 47-k Ω resistor using a BNC-to-clip-lead cable.
- Connect Input A to TP24 (initially) using a BNC-to-clip-lead cable.
- Make sure that the ground from either the Input A or Input B connector is connected to the 1986 ground (negative side of C12).

- b. Set the 1192 as follows:

INPUT ATTEN	10:1
RATIO	depressed
TRIGGER LEVEL	mid range
AC/DC	AC
DISPLAY	1 s or less
PERIODS OR RATIOS AVERAGED	1
STORAGE (REAR PANEL)	depressed

c. Set the 1986 as follows:

FREQUENCY any setting (1 kHz is automatically generated in **fast** mode)
 LEVEL 114 dB
 VARIABLE SPL **fast**
 SPL ADJUST fully clockwise

d. Select the 1986 controls as indicated in Table 5-7. Connect the 1192 INPUT A to TP24, and then to TP4 (see Figure 5-2). Note the counter reading in each case; it should be within the tolerance indicated on the expected readings. Notice that a new count will not necessarily occur on each tone burst.

Table 5-7
 READINGS FOR TIME-FUNCTION CHECK

1986 VARIABLE SPL Position	1986 LEVEL Position (dB)	1192 RATIOS AVERAGED Position	Expected Reading (in dB)* With 1192 Connected to:	
			TP24	TP4
fast	114	1	200 ± 1	2,000 ± 5
slow	114	1	500 ± 1	10,000 ± 5
crest factor	104	10	110 ± 1	500 ± 2

*Counter's trigger level must be properly set to obtain correct reading.

5.6.8 Crest-Factor Burst Level.

- Connect the DVM to TP4 and ground on the 1986 (see Figure 5-2).
- Set the 1986 as follows:

FREQUENCY any setting (2 kHz is automatically generated in **set crest fctr** mode)
 LEVEL 104 dB
 VARIABLE SPL **set crest fctr**

c. Set the SPL ADJUST control for an indication of 200 mV on the DVM.

d. Change the VARIABLE SPL control to **crest factor**. The DVM should now indicate 426 ± 4 mV. The change from 200 mV to 426 mV represents a difference of 6.58 dB.

5.6.9 Background Level.

- Connect the DVM to the 1986 AC OUTPUT connector.
- Set the 1986 as follows:

FREQUENCY any setting (1 kHz is automatically generated in **set fast/slow** mode)
 LEVEL 114 dB
 VARIABLE SPL **set fast/slow**

- c. Set the SPL ADJUST for an indication of 500 mV on the DVM.
- d. Set the 1986 VARIABLE SPL control to **slow**; between bursts, the DVM must indicate 50 ± 5 mV.

5.6.10 Acoustical-Output Level.

Special facilities are required to calibrate the output level of the 1986 so that it, in turn, can be used to calibrate sound-measuring instruments in accordance with ANSI and IEC specifications. Such facilities are available at the GenRad factory and service centers, and are used in the initial factory calibration or repair of a 1986. These facilities must include a standard microphone, such as the Western Electric Co. 640AA or its equivalent, that possesses a known level traceable to the National Bureau of Standards.

Potentiometer R39 (see Figure 5-2) is first adjusted at 1 kHz for a level of 114 dB re 20 μ Pa. Potentiometers R43, 44, 46, 47, and 48 are then adjusted for 114 dB at 4 kHz, 2 kHz, 500 Hz, 250 Hz and 125 Hz, respectively. These controls are normally glyptolled in place at the time of original calibration, and they should not be tampered with unless a full calibration facility exists.

5.7 TROUBLE ANALYSIS.

When a malfunction is suspected in the 1986, it is first recommended that the performance verification procedure of para 5.3 be performed. This will usually establish if there is a problem with the unit. The 1986 should only be serviced by persons skilled in the repair of delicate electronic equipment.

CAUTION

Service personnel, observe the special HANDLING PRECAUTIONS at the beginning of this section before performing any work on the calibration board in this instrument.

Detailed schematics and parts lists are included in Section 6, and circuit descriptions in Section 4. The schematics have many waveforms and voltages to aid in troubleshooting procedures. If the 1986 undergoes any repair that will alter its acoustical output, it is essential that the test and calibration procedure described in para 5.6 be performed. It is important to note that a special calibration facility is required for the acoustical calibration described in para 5.6.10.

Parts Lists and Diagrams – Section 6

NOTE

Electrical-parts information in this section is presented in such a way that all the component and circuit data are visible in a single opening of the manual. Thus, the etched-board part-location diagram appears on a left-hand tip-out page, while the electrical-parts list is on the apron and the 2 schematic diagrams are on right-hand tip-out pages.

REFERENCE DESIGNATOR ABBREVIATIONS

B	=	Motor	P	=	Plug
BT	=	Battery	Q	=	Transistor
C	=	Capacitor	R	=	Resistor
CR	=	Diode	S	=	Switch
DS	=	Lamp	T	=	Transformer
F	=	Fuse	U	=	Integrated Circuit
J	=	Jack	VR	=	Diode, Zener
K	=	Relay	X	=	Socket for Plug-In
KL	=	Relay Coil	Y	=	Crystal
KS	=	Relay Switch	Z	=	Network
L	=	Inductor			
M	=	Meter			
MK	=	Microphone			

References
ASA Y32.16 and MIL-STD-167

6.1 MECHANICAL PARTS.

Figures 6-1, 6-2 and 6-3 show locations of mechanical parts on the GR 1986; adjacent tables list descriptions and associated GR and manufacturers' part numbers.

6.2 ELECTRICAL-PARTS LIST AND DIAGRAMS.

Figures 6-4, 6-5, 6-6 and 6-7 are, respectively, the block diagram, etched-board diagram, analog schematic diagram and digital schematic diagram of the circuits and components in the 1986. An electrical-parts list gives descriptions and part numbers for the electrical components shown in these figures.

6.3 FEDERAL MANUFACTURERS' CODE.

The code numbers of all manufacturers that supply parts for this instrument are listed on a tip-out page in this section. The applicable code numbers for specific parts are given in the mechanical and electrical-parts lists.

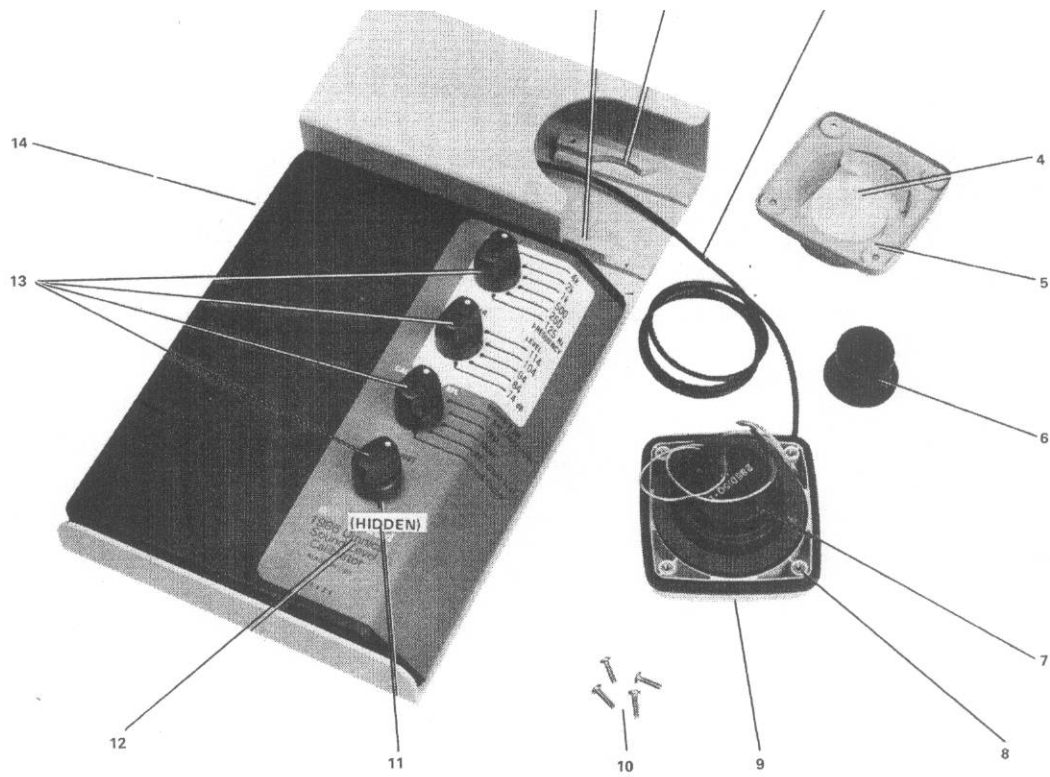

Figure 6-1. Mechanical parts on front panel and transducer assembly.

MECHANICAL PARTS ON FRONT PANEL AND TRANSDUCER ASSEMBLY

Fig. 6-1 Ref. No.	Name	Description/Purpose	GR P/N	Fed. Mfg. Code	Mfg. P/N	Qty
1	Clamp, Left	Plastic, flexible; secures transducer assembly.	1986-7050	24655	1986-7050	1
2	Clamp, Right	Plastic, flexible; secures transducer assembly.	1986-7055	24655	1986-7050	1
3	Transducer Cable	Twist-shield type; extension of transducer assembly.	1986-0200	24655	1986-0200	1
4	Desiccant Kit	Contains 2 desiccants (silicon-gel activated, disk-shaped) and 1 indicator.	5863-3002	24655	5863-3002	1
5	Housing, Transducer Top	Plastic; contains desiccant window.	1986-7000	24655	1986-7000	1
6	Microphone Adaptor	Molded plastic; adapts transducer cavity to 1/2-in. microphone.	1987-7061	24655	1987-7061	1
7	Transducer	Electromagnetic, aluminum diaphragm; converts electrical signal to acoustical output.	1986-1020	24655	1986-1020	1
8	Gasket, Housing	Styrene butadiene elastomer; provides moisture and dust control.	1986-7045	24655	1986-7045	1
9	Housing, Transducer Bottom	Plastic; contains transducer assembly and includes 1-in. cavity for microphone insertion.	1986-2035	24655	1986-2035	1
10	Screw	Pan-head, 0.112-40x 0.375-in.; secures top housing to bottom housing of transducer assembly.	7044-1103	24655	7044-1103	4
11	Gasket, Switch	Circular; separates 1986-1000 cover from S1, S2, S3 and R20 assemblies.	1986-7060	24655	1986-7060	4
12	Label	Satin finish; contains markings for panel controls and instrument identification.	1986-0410	24655	1986-0410	4
13	Knob, Bar	Plastic; fits on shaft of S1, S2, S3 or R20.	5500-5226	24655	5500-5226	4
14	Cover	Aluminum, black; covers circuit board; secured by six 7044-1103 screws.	1986-1000	24655	1986-1000	1

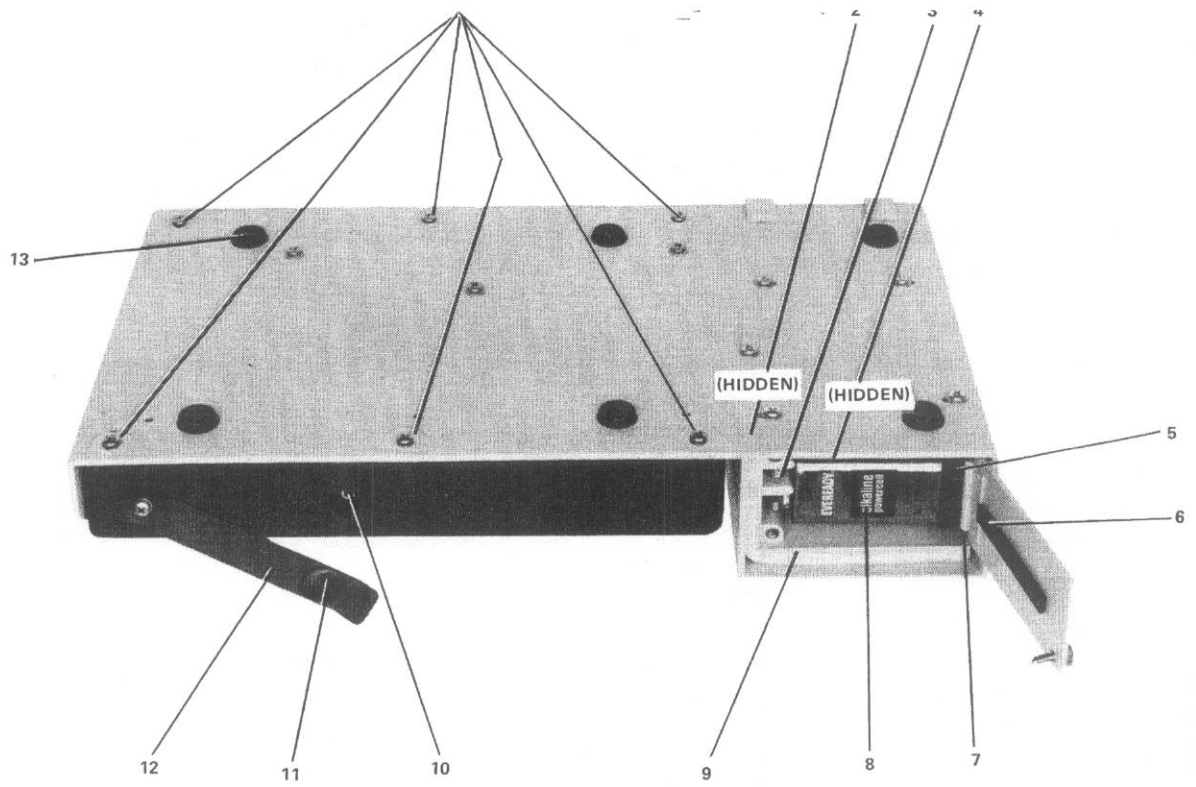

Figure 6-2. Mechanical parts on side and rear panels.

MECHANICAL PARTS ON SIDE AND REAR PANELS

Fig. 6-2 Ref. No.	Name	Description/Purpose	GR P/N	Fed. Mfg. Code	Mfg. P/N	Qty
1	Screw	Pan-head, 0.112-40x 0.375-in.; secures 1986-1000 cover to chassis (see Figure 5-1).	7044-1103	24655	7044-1103	6
1	Washer	Security, 7x3.0x0.5; goes with 7044-1103 screw.	8140-3007	24655	8140-3007	6
2	Cable, Battery	23-cm (9-in.), double-lead molded cable; connects battery contacts to circuit board.	1986-0210	24655	1986-0210	1
3	Contact, Battery	Spring metal; connects battery to 1986-0210 cable.	1987-8010	24655	1987-8010	2
4	Pad	Foam, adhesive; compresses and locates battery in battery case.	5155-4731	24655	5155-4731	1
5	Pad	Foam, adhesive; compresses and locates battery in battery case.	1986-7015	24655	1986-7015	1
6	Pad	Foam, adhesive; cushions cover against battery.	1986-7030	24655	1986-7030	1
7	Pin, Battery Cover	Metal; inserts into hinge of battery cover.	1986-6010	24655	1986-6010	1
8	Battery	9-V alkaline; provides power to instrument.	8410-3400	90303	MN1604INS	1
9	Battery Case	Plastic; contains battery; includes outline for proper polarization.	1986-2020	24655	1986-2020	1
10	Connector	Miniature jack, 0.097-in. diameter, AC OUTPUT (J3); accepts Switchcraft Type 850 miniature plug (GR P/N 4270-1110).	4260-1110	82389	TR-2A	1
11	Button, Snap	Nylon back; 0.359-in.; covers AC OUTPUT jack (J3).	4160-0250	02768	207-230201-00-0108	1
12	Strap	Plastic; contains 4160-0250 snapbutton.	1986-7035	24655	1986-7035	1
13	Foot	Adhesive-backed rubber foot; prevents direct contact of chassis with outside surfaces.	5260-2070	24655	5260-2070	6

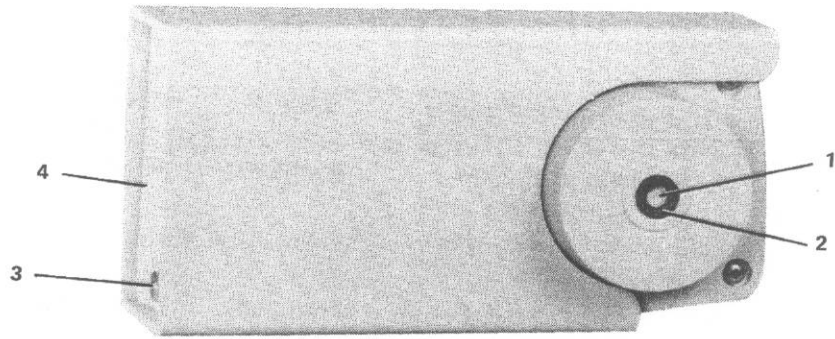

Figure 6-3. Mechanical parts on top section.

MECHANICAL PARTS ON TOP SECTION

Fig. 6-3 Ref. No.	Name	Description/Purpose	GR P/N	Fed. Mfg. Code	Mfg. P/N	Qty
1	Window, Desiccant	Clear plastic; provides observation of desiccant indicator.	1986-7070	24655	1986-7070	1
2	Frame, Window	Styrene butadiene elastomer; provides moisture and dust control.	1987-7085	24655	1987-7085	1
3	Screw, Cover	0.112-40 thread; includes knurled head; secures battery cover.	1987-6001	24655	1987-6001	1
4	Cover, Battery	Aluminum, gray; includes hinge, pad, and knurled-head screw; protects battery compartment.	1986-2000	24655	1986-2000	1

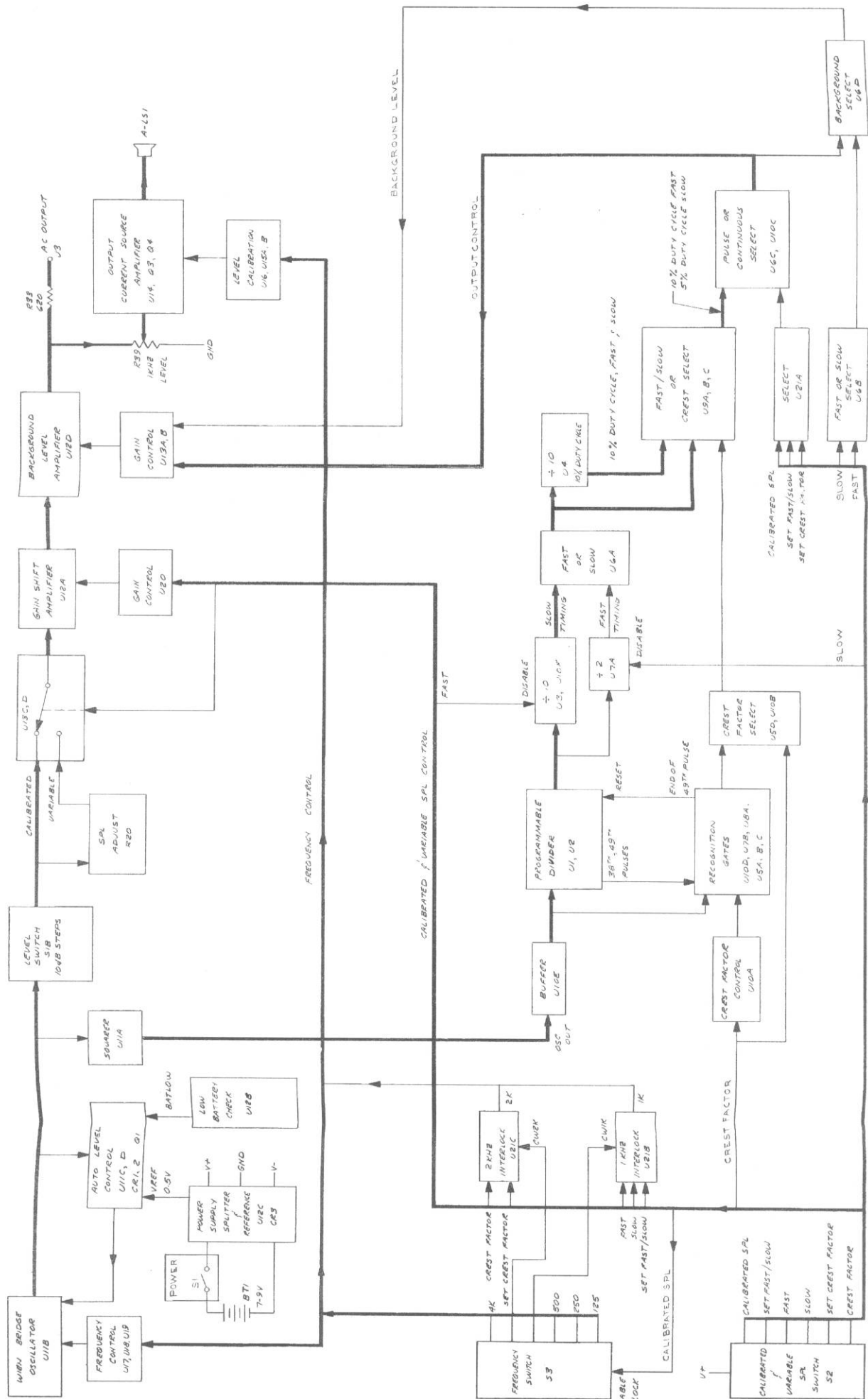
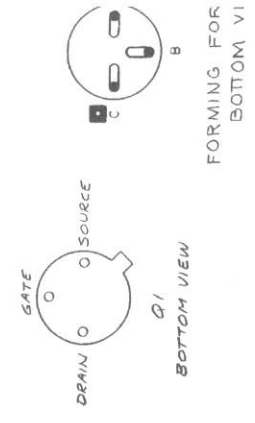

Figure 6-4. Block

CAUTION
 THE FOLLOWING COMPONENTS
 REQUIRE SPECIAL HANDLING
 FOR STATIC PROTECTION
 REFER TO ESPM-247
 U1-11, 13-21, Q1



FORMING FOR
 BOTTOM VI

BOTTOM VIEW

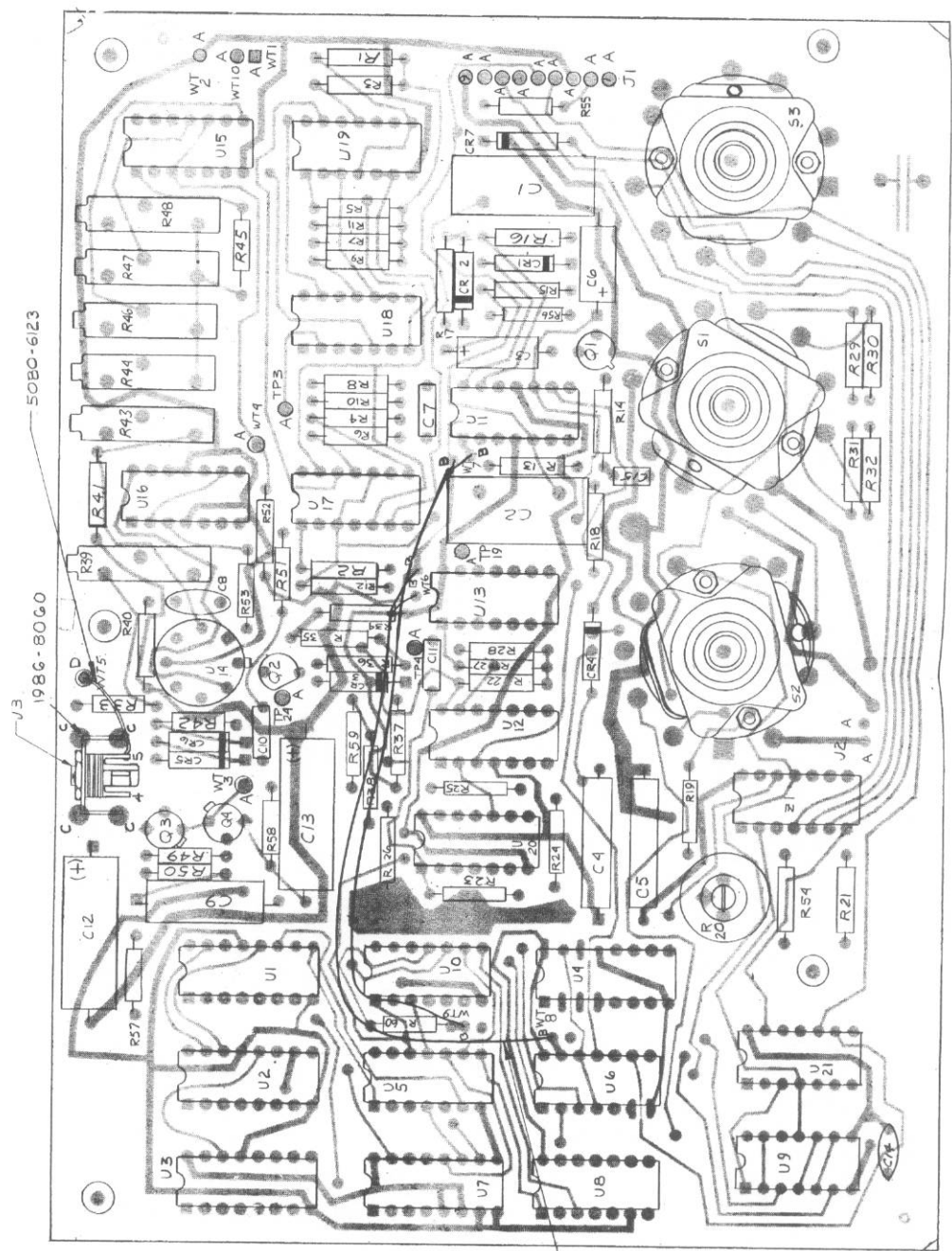

Figure 6-5

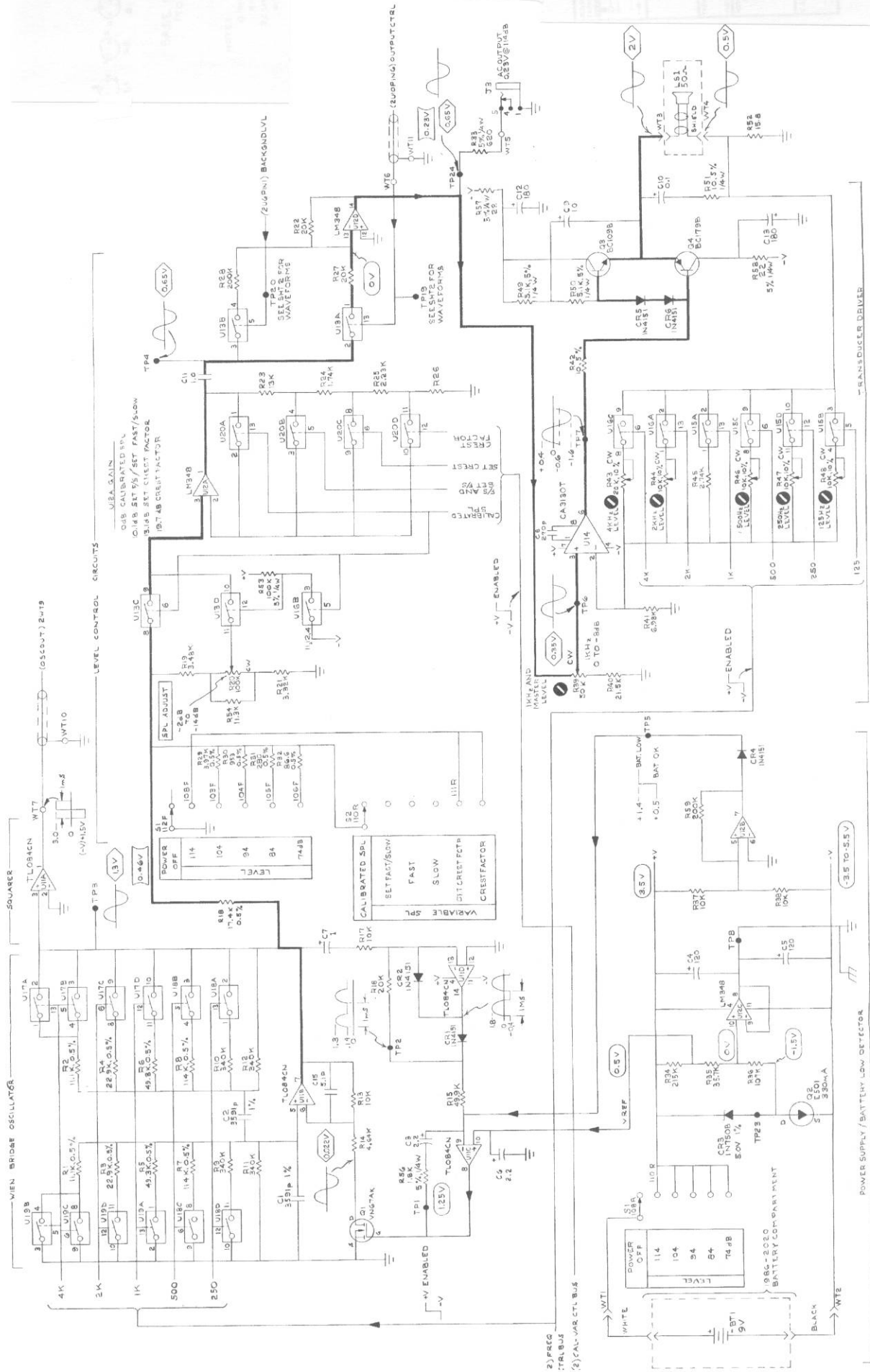

Figure 6-6. Analog schematic diagram

SOUND INSTRUMENTATION CALIBRATION CHARTS

Instrument Type _____ Tested By _____

Serial Number _____ Date _____

Freq (Hz)	A-Weighting		B-Weighting		C-Weighting	
	Reading (dB)	Corrected Reading from Table A* (dB)	Reading (dB)	Corrected Reading from Table A* (dB)	Reading (dB)	Corrected Reading from Table A* (dB)
125						
250						
1000		(ref.)		(ref.)		(ref.)
2000		X		X		X
4000						

*See Condensed Operating Instructions

1986 Level (dB)	Instrument Under Test	
	Meter Reading (dB)	Digital Reading (dB)
Full-Scale Level on Instrument Under Test (Reference Level)	X	X
-10 dB down from Full Scale		
-20 dB down from Full Scale		
-30 dB down from Full Scale		
-40 dB down from Full Scale		

1986 Level (dB)	Instrument Under Test	
	Meter Reading (dB)	Digital Reading (dB)
Reference Level (94 dB recommended)		X
104		
114		
84		
74		

RMS-ACCURACY TEST	Meter Reading (dB)	
	OK	Digital Reading (dB)
Reference Level	X	X
Crest-Factor Level		

DYNAMIC-CHARACTERISTICS TEST		
Max Meter Reading (dB)	OK	Max Digital Reading (dB)
Reference Level	X	X
Fast-Response Level		
Slow-Response Level		

ELECTRICAL PARTS LIST

CALIBRATOR PC BOARD P/N 1986-4700

REFDES	DESCRIPTION	PART NO.	FMC	MFG#	PART NUMBER	DESCRIPTION	PART NO.	FMC	MFG#	PART
C 1	CAP MICA 3591 PF	4851-0272	72136		DM20F03591PF1PCT4CR	RES FLM 21.5K	6250-2215	81349	RM55D2152F	
C 2	CAP MICA 3591 PF	4851-0272	72136		DM20F03591PF1PCT4CR	RES FLM 6.99K	6250-1698	81349	RM55D06981F	
C 3	CAP TANT 2.2 UF	4450-4510	56289		150D225X9020A2	RES COMP 10 OHM	6099-0105	81349	RCR07G100J	
C 4	CAP TANT 120 UF	4450-6301	90201		MTP 120UF 20PCT 10V	POT CERM TRM 20K OHM	6049-0190	80294	3006P-1-203	
C 5	CAP TANT 120 UF	4450-6301	90201		MTP 120UF 20PCT 10V	POT CERM TRM 20K OHM	6049-0189	80294	3006P-1-103	
C 6	CAP TANT 2.2 UF	4450-4510	56289		150D225X9020A2	RES FLM 2.74K	6250-1274	81349	RM55D2741F	
C 7	CAP CER MONO	4400-2070	72982		150D225X9020A2	POT CERM TRM 10K OHM	6049-0189	80294	3006P-1-103	
C 8	CAP CER DISC	270PF	56289		8131-M050-651-105M	POT CERM TRM 10K OHM	6049-0189	80294	3006P-1-103	
C 9	CAP TANT 10 UF	4450-5100	56289		083108225D000271J	POT CERM TRM 10K OHM	6049-0189	80294	3006P-1-103	
C 10	CAP CER MONO	0-1UF	20PCT	50VGP	150D106X002082	POT CERM TRM 10K OHM	6099-2515	81349	RCR07G512J	
C 11	CAP CER MONO	10UF	20PCT	50VGP	8131-M050-651-104M	RES COMP 5.1K	6099-2515	81349	RCR07G512J	
C 12	CAP TANT 180 UF	4450-5617	56289		150D187X000682	RES COMP 5.1K	6099-2515	81349	RCR07G512J	
C 13	CAP TANT 180 UF	4450-5617	56289		150D187X000682	RES COMP 5.1K	6099-2515	81349	RCR07G512J	
C 14	CAP CER DISC	680PF	56289		083108225D000680J	RES COMP 10 OHM	6099-0105	81349	RCR07G100J	
C 15	CAP CER SQ	5.1PF	5PCT	100V NPO	8101A1010CG0519J	RES COMP 10 OHM	6099-0105	81349	RCR07G100J	
CR 1	DIODE IN4151	75P1V	IR.1UA	SI	IN3604	RES COMP 1.0K	6099-4105	81349	RCR07G104J	
CR 2	DIODE IN4151	75P1V	IR.1UA	SI	IN3604	RES COMP 1.0K	6099-4105	81349	RCR07G104J	
CR 3	ZENER C0XXX	5.0V	1PCT	.4W	6083-1102	RES COMP 1.8K	6099-2185	81349	RCR07G182J	
CR 4	DIODE IN4151	75P1V	IR.1UA	SI	IN3604	RES COMP 22 OHM	6099-0225	81349	RCR07G220J	
CR 5	DIODE IN4151	75P1V	IR.1UA	SI	IN3604	RES COMP 22 OHM	6099-0225	81349	RCR07G220J	
CR 6	DIODE IN4151	75P1V	IR.1UA	SI	IN3604	RES FLM 200K	6250-3200	81349	RM55D2003F	
CR 7	DIODE IN4151	75P1V	IR.1UA	SI	IN3604	RES COMP 10K	6099-3105	81349	RCR07G103J	
J 1	JUMPER ASM	1986-0220	24655		1986-0220	SWITCH ROTARY	7890-8430	24655	7890-8430	
J 2	CONN 2FEM	CONN JUMPR.025P	82526		65474-001	SWITCH ROTARY	7890-8430	24655	7890-8430	
J 3	MINATURE PHONE 2 CKT	SW	82389		TR-2A	SWITCH ROTARY	7890-8430	24655	7890-8430	
Q 1	TRANSISTOR	8C-1098	17856		VN67AK	ICD (STATIC PROTECT REQ)	5431-7001	86684	CD4017AE	
Q 2	TRANS E-501	CS-33MA	17856		E501	ICD (STATIC PROTECT REQ)	5431-7001	86684	CD4017AE	
Q 3	TRANSISTOR	8C-1098	27014		8C-1098	ICD (STATIC PROTECT REQ)	5431-7001	86684	CD4017AE	
Q 4	TRANSISTOR	8C-1798	27014		8C-1798	ICD (STATIC PROTECT REQ)	5431-7004	86684	CD4001AE	
R 1	RES FLM 11.1K	1/2PCT	1/8W		RM55D1112D	ICD (STATIC PROTECT REQ)	5431-7001	86684	CD4017AE	
R 2	RES FLM 11.1K	1/2PCT	1/8W		RM55D1112D	ICD (STATIC PROTECT REQ)	5431-7001	86684	CD4017AE	
R 3	RES FLM 22.9K	1/2PCT	1/8W		RM55D2292D	ICD (STATIC PROTECT REQ)	5432-7001	01295	TL084CN	
R 4	RES FLM 22.9K	1/2PCT	1/8W		RM55D2292D	ICD (STATIC PROTECT REQ)	5432-7001	01295	TL084CN	
R 5	RES FLM 49.3K	1/2PCT	1/8W		RM55D4932D	ICD (STATIC PROTECT REQ)	5431-7047	04713	MC14068BCP	
R 6	RES FLM 49.3K	1/2PCT	1/8W		RM55D4932D	ICD (STATIC PROTECT REQ)	5431-7047	04713	MC14068BCP	
R 7	RES FLM 114K	1/2PCT	1/8W		RM55D1143D	ICD (STATIC PROTECT REQ)	5431-7020	86684	CD4001AE	
R 8	RES FLM 114K	1/2PCT	1/8W		RM55D1143D	ICD (STATIC PROTECT REQ)	5431-7014	86684	CD4013AE	
R 9	RES FLM 340K	1 PCT	1/8W		RM55D3403F	ICD (STATIC PROTECT REQ)	5431-7044	04713	MC14069BCP	
R 10	RES FLM 340K	1 PCT	1/8W		RM55D3403F	ICD (STATIC PROTECT REQ)	5432-7001	01295	TL084CN	
R 11	RES FLM 340K	1 PCT	1/8W		RM55D3403F	ICD (STATIC PROTECT REQ)	5431-7047	04713	MC140668CP	
R 12	RES FLM 340K	1 PCT	1/8W		RM55D3403F	ICD (STATIC PROTECT REQ)	5431-7047	04713	MC140668CP	
R 13	RES FLM 10.0K	1 PCT	1/8W		RM55D1002F	ICD (STATIC PROTECT REQ)	5431-7047	04713	MC140668CP	
R 14	RES FLM 4.64K	1 PCT	1/8W		RM55D4641F	ICD (STATIC PROTECT REQ)	5431-7047	04713	MC140668CP	
R 15	RES FLM 4.64K	1 PCT	1/8W		RM55D4641F	ICD (STATIC PROTECT REQ)	5431-7047	04713	MC140668CP	
R 16	RES FLM 20K	1 PCT	1/8W		RM55D2002F	ICD (STATIC PROTECT REQ)	5431-7047	04713	MC140668CP	
R 17	RES FLM 10.0K	1 PCT	1/8W		RM55D1002F	ICD (STATIC PROTECT REQ)	5431-7047	04713	MC140668CP	
R 18	RES FLM 17.4K	1/2PCT	1/8W		RM55D1742D	ICD (STATIC PROTECT REQ)	5431-7047	04713	MC140668CP	
R 19	RES FLM 3.48K	1 PCT	1/8W		RM55D3481F	ICD (STATIC PROTECT REQ)	5431-7051	04713	MC14075BCP	
R 20	THYRECTOR	60 VOLTS			K2ZDTM	RES NETWORK	6740-2510	80294	4114R-0002-	
R 21	RES FLM 3.32K	1 PCT	1/8W		RM55D3321F	RES NETWORK	6740-2510	80294	4114R-0002-	
R 22	RES FLM 20K	1 PCT	1/8W		RM55D2002F	RES NETWORK	6740-2510	80294	4114R-0002-	
R 23	RES FLM 13.0K	1 PCT	1/8W		RM55D1302F	RES NETWORK	6740-2510	80294	4114R-0002-	
R 24	RES FLM 1.74K	1 PCT	1/8W		RM55D1741F	RES NETWORK	6740-2510	80294	4114R-0002-	
R 25	RES FLM 2.23K	1 PCT	1/8W		RM55D2231F	RES NETWORK	6740-2510	80294	4114R-0002-	
R 26	RES FLM 1.96K	1/2PCT	1/8W		RM55D1961D	RES NETWORK	6740-2510	80294	4114R-0002-	
R 27	RES FLM 20K	1 PCT	1/8W		RM55D2002F	RES NETWORK	6740-2510	80294	4114R-0002-	
R 28	RES FLM 200K	1 PCT	1/8W		RM55D2003F	RES NETWORK	6740-2510	80294	4114R-0002-	
R 29	RES FLM 3.97K	1/2PCT	1/8W		RM55D3971D	RES NETWORK	6740-2510	80294	4114R-0002-	
R 30	RES FLM 953 OHM	1/2PCT	1/8W		RM55D9530D	RES NETWORK	6740-2510	80294	4114R-0002-	
R 31	RES FLM 280 OHM	1/2PCT	1/8W		RM55D2800D	RES NETWORK	6740-2510	80294	4114R-0002-	
R 32	RES FLM 86.6 OHM	1/2PCT	1/8W		RM55D8666D	RES NETWORK	6740-2510	80294	4114R-0002-	
R 33	RES COMP 620 OHM	5PCT	1/4W		RCR07G621J	RES NETWORK	6740-2510	80294	4114R-0002-	
R 34	RES FLM 215K	1 PCT	1/8W		RM55D2153F	RES NETWORK	6740-2510	80294	4114R-0002-	
R 35	RES FLM 35.7K	1 PCT	1/8W		RM55D3572F	RES NETWORK	6740-2510	80294	4114R-0002-	
R 36	RES FLM 10.7K	1 PCT	1/8W		RM55D1073F	RES NETWORK	6740-2510	80294	4114R-0002-	
R 37	RES FLM 10.0K	1 PCT	1/8W		RM55D1002F	RES NETWORK	6740-2510	80294	4114R-0002-	
R 38	RES FLM 10.0K	1 PCT	1/8W		RM55D1002F	RES NETWORK	6740-2510	80294	4114R-0002-	
R 39	POT CERM TRM	50K OHM	10 PCT	15T	3006P-1-503	RES NETWORK	6740-2510	80294	4114R-0002-	

Appendix

USE OF THE NOMOGRAPH.

CORRECTION OF BAROMETRIC PRESSURE TO STATION ALTITUDE.

To obtain a corrected barometric pressure for a station:

- Determine the station's altitude above sea level from the appropriate chart in this section.
- Obtain a barometric-pressure reading corrected to sea level from a barometer. (If the barometer reads only values in mm, find the corresponding value of mbar from the right-hand scales).
- Place a straight-edge across the proper points on the center and left-hand scales of the nomograph, and read the actual pressure at the station on the right-hand scales.

CONVERSION FROM MILLIMETERS OF MERCURY TO INCHES OF MERCURY.

To convert from mm of mercury to in. of mercury, proceed as follows:

- Find the barometric-pressure value in mm of mercury on the right-hand scale.
- Obtain the corresponding value in mbar from the same scale.
- Move to the left-hand scale and find the mbar value obtained in step b.
- Read the corresponding value of barometric pressure in in. of mercury from the left-hand scale.

NOMOGRAPH FOR APPLYING ALTITUDE CORRECTION TO BAROMETRIC PRESSURE

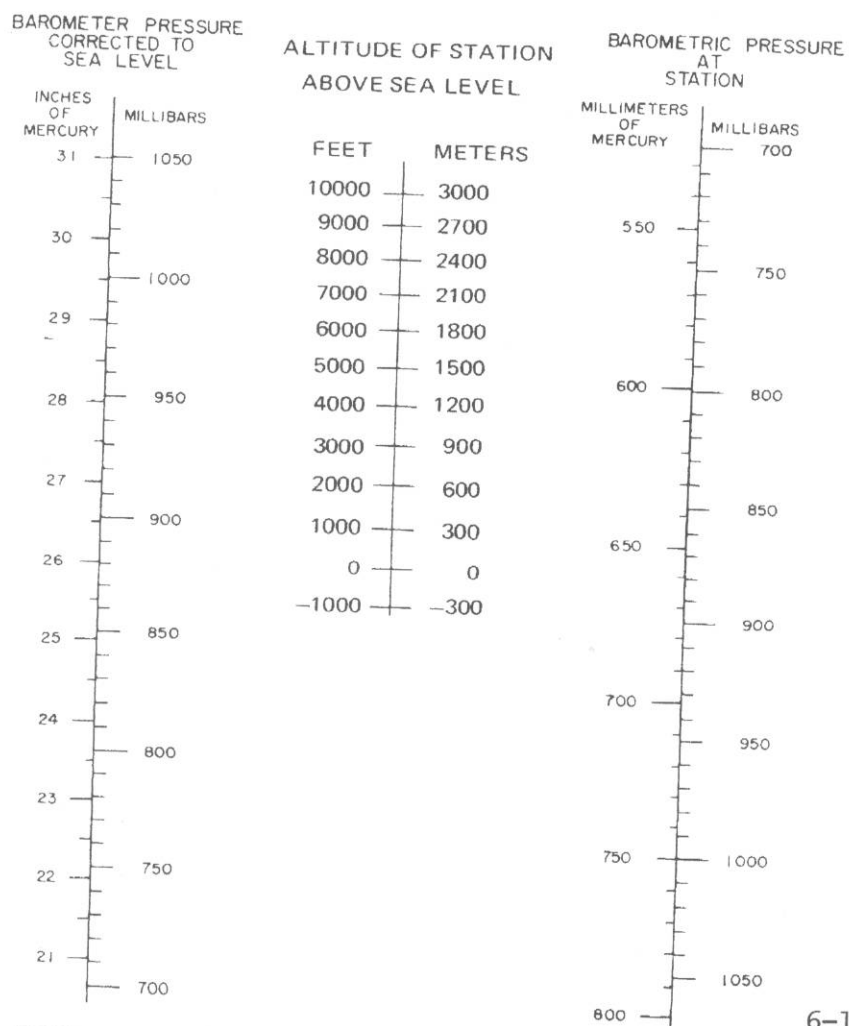

NOTE: 1 ft = 0.3048 m

ALTITUDES ABOVE SEA LEVEL FOR SELECTED
CITIES IN U.S. AND CANADA

<i>City</i>	<i>Feet Above Sea Level</i>	<i>City</i>	<i>Feet Above Sea Level</i>
Akron, Ohio	950	London, Ontario	804
Albany, New York	20	Los Angeles, California	292
Allentown, Pennsylvania	320	Louisville, Kentucky	454
Ashland, Kentucky	530	Manchester, New Hampshire	210
Atlanta, Georgia	1105	Memphis, Tennessee	238
Augusta, Georgia	141	Miami, Florida	15
Baltimore, Maryland	81	Milwaukee, Wisconsin	609
Bangor, Maine	21	Minneapolis, Minnesota	826
Bay City, Michigan	593	Mobile, Alabama	15
Binghamton, New York	865	Moncton, N.B.	50
Birmingham, Alabama	598	Montgomery, Alabama	191
Boise, Idaho	2717	Montreal, P.Q.	110
Boston, Massachusetts	45	Nashville, Tennessee	498
Brandon, Man.	1204	Newark, New Jersey	43
Buffalo, New York	590	New Haven, Connecticut	21
Burlington, Vermont	190	New London, Connecticut	27
Bridgeport, Connecticut	12	New Orleans, Louisiana	5
Calgary, Alta.	3439	New York, New York	35
Cambridge, Massachusetts	80	Norfolk, Virginia	38
Camden, New Jersey	30	Oakland, California	18
Campbellton, N.B.	42	Omaha, Nebraska	1040
Charleston, South Carolina	13	Ottawa, Ontario	200
Charlotte, North Carolina	734	Patterson, New Jersey	117
Charlottetown, P.E.I.	8	Peoria, Illinois	465
Chicago, Illinois	604	Philadelphia, Pennsylvania	150
Cleveland, Ohio	600	Phoenix, Arizona	1085
Colorado Springs, Colorado	6012	Pittsburg, Pennsylvania	742
Columbus, Georgia	261	Portland, Maine	34
Columbus, Ohio	759	Portland, Oregon	69
Council Bluffs, Iowa	989	Providence, Rhode Island	43
Dallas, Texas	437	Quebec, P.Q.	20
Dartmouth, N.S.	14	Racine, Wisconsin	619
Davenport, Iowa	571	Regina, Sask.	1414
Dayton, Ohio	743	Reno, Nevada	4487
Denver, Colorado	5227	Richmond, Virginia	84
Des Moines, Iowa	626	Rochester, New York	509
Duluth, Minnesota	626	Saint John, N.B.	21
Edmonton, Alta.	2183	Saint Louis, Missouri	460
Elizabeth, New Jersey	28	Saint Paul, Minnesota	754
Erie, Pennsylvania	709	Salt Lake City, Utah	4300
Evansville, Indiana	380	Sacramento, California	30
Flint, Michigan	716	San Antonio, Texas	657
Fort Smith, Arkansas	445	San Francisco, California	50
Fort Wayne, Indiana	780	Saskatoon, Sask.	1596
Fort Worth, Texas	600	Savannah, Georgia	42
Fredericton, N.B.	32	Scranton, Pennsylvania	757
Galveston, Texas	28	Seattle, Washington	51
Grand Rapids, Michigan	628	Shreveport, Louisiana	217
Great Falls, Montana	3309	Sioux Falls, South Dakota	1405
Halifax, N.S.	59	South Bend, Indiana	718
Hamilton, Ontario	300	Spokane, Washington	1905
Harrisburg, Pennsylvania	355	Springfield, Massachusetts	101
Hartford, Connecticut	36	Sydney, N.S.	10
Houston, Texas	48	Syracuse, New York	410
Huntington, West Virginia	565	Tacoma, Washington	87
Indianapolis, Indiana	749	Toledo, Ohio	594
Jackson, Mississippi	286	Toronto, Ontario	250
Jacksonville, Florida	25		

ALTITUDES ABOVE SEA LEVEL FOR SELECTED
CITIES IN U.S. AND CANADA

<i>City</i>	<i>Feet Above Sea Level</i>	<i>City</i>	<i>Feet Above Sea Level</i>
Jersey City, New Jersey	44	Topeka, Kansas	909
Kansas City, Missouri	750	Tucson, Arizona	2382
Knoxville, Tennessee	895	Tulsa, Oklahoma	700
Lansing, Michigan	842	Utica, New York	448
Lexington, Kentucky	966	Vancouver, B.C.	18
Lincoln, Nebraska	1169	Washington, D.C.	100
Little Rock, Arkansas	286	Wichita, Kansas	1285
		Windsor, Ontario	580

ALTITUDES ABOVE SEA LEVEL FOR
SELECTED INTERNATIONAL CITIES

<i>City</i>	<i>Altitude Above Sea Level</i>	
	<i>Meters</i>	<i>Feet</i>
Adelaide, Australia	11	35
Amman, Jordan	665	2400
Amsterdam, Netherlands	50	16
Ankara, Turkey	640	2250
Athens, Greece	92	300
Belgrade, Yugoslavia	138	450
Berlin, Germany	35	115
Bombay, India	8	25
Brussels, Belgium	58	190
Buenos Aires, Argentina	14	45
Cairo, Egypt	30	98
Canberra, Australia	900	2000
Copenhagen, Denmark	76	25
Johannesburg, U.S. Africa	1750	5689
Lahore, Pakistan	210	706
La Paz, Bolivia	3700	12200
London, England	74	245
Manila, Philippines	8	25
Melbourne, Australia	10	30
Mexico City, Mexico	2200	7349
Munich, Germany	510	1700
Paris, France	42	300
Prague, Czech.	175	575
Rome, Italy	28	95
Santiago, Chile	550	1800
San Paulo, Brazil	820	2700
Seoul, Korea	78	250
Stockholm, Sweden	11	35
Tokyo, Japan	10	30
Warsaw, Poland	73	240
Zurich, Switzerland	400	1360